

Operating Instructions

Maintenance Guide

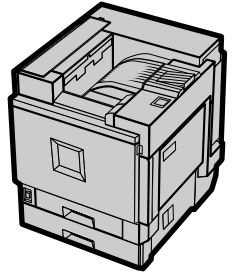

-
- 1** Replacing Consumables and Maintenance Kit
 - 2** Cleaning and Adjusting the Printer
 - 3** Paper and Other Media
 - 4** Troubleshooting
 - 5** Appendix

Introduction

This manual describes detailed instructions on the operation and notes about the use of this machine. To get maximum versatility from this machine all operators are requested to read this manual carefully and follow the instructions. Please keep this manual in a handy place near the machine.

Trademarks

Microsoft, Windows, and Windows NT are registered trademarks of Microsoft Corporation in the United States and/or other countries.

Other product names used herein are for identification purposes only and might be trademarks of their respective companies. We disclaim any and all rights involved with those marks.

Notes:

Some illustrations in this manual might be slightly different from the machine. Certain options might not be available in some countries. For details, please contact your sales or service representative.

Note

The proper names of the Windows operating systems are as follows:

- The product name of Windows[®] 95 is Microsoft[®] Windows[®] 95.
- The product name of Windows[®] 98 is Microsoft[®] Windows[®] 98.
- The product name of Windows[®] Me is Microsoft[®] Windows[®] Millennium Edition (Windows Me).
- The product names of Windows[®] 2000 are as follows:
 - Microsoft[®] Windows[®] 2000 Advanced Server
 - Microsoft[®] Windows[®] 2000 Server
 - Microsoft[®] Windows[®] 2000 Professional
- The product names of Windows[®] XP are as follows:
 - Microsoft[®] Windows[®] XP Professional
 - Microsoft[®] Windows[®] XP Home Edition
- The product names of Windows NT[®] 4.0 are as follows:
 - Microsoft[®] Windows NT[®] Server 4.0
 - Microsoft[®] Windows NT[®] Workstation 4.0

TABLE OF CONTENTS

Trademarks.....	i
-----------------	---

1. Replacing Consumables and Maintenance Kit

Using the Screwdriver	1
Replacing the Toner Cartridge	2
Detaching the SR770 (2 Tray Finisher)	5
Opening and Closing the Duplex Reversal Unit	6
Replacing the Fuser Oil Unit.....	7
Replacing the Photoconductor Unit.....	11
Replacing the Development Unit.....	15
Replacing the Fusing Unit.....	19
Replacing the Dustproof Filter	22
Replacing the Waste Toner Bottle.....	24
Replacing the Paper Feed Rollers.....	26

2. Cleaning and Adjusting the Printer

Cautions to Take When Cleaning	29
Cleaning the Registration Roller	30
Cleaning the DustProof Glass	31
Adjusting the Color Registration.....	32
Auto Adjust.....	32
Adjusting the Fuser for Thick Paper.....	33
Test Sheet Samples.....	35
Adjusting Image Density	36
Adjusting Tray Registration.....	37

3. Paper and Other Media

Paper and Other Supported Media.....	39
Paper Sizes.....	39
Paper Recommendations.....	45
Loading Paper.....	45
Storing Paper	45
Types of Paper and Other Media	45
Printable Area.....	49
Loading Paper	50
Loading Paper in Tray 1	50
Loading Paper in Tray 2 and the Optional Paper Feed Unit	51
Loading paper in Paper Bank PS470 (2000-sheet Large Capacity Tray)	52
If you load a paper size that is not selected automatically	53
Changing the paper type.....	55
Loading Paper in the Bypass Tray	56

4. Troubleshooting

Error & Status Messages on the Control Panel	61
Printer Does Not Print	74
Other Printing Problems	77
Removing Misfed Paper	81
Detaching the 2 Tray Finisher	81
Opening and Closing the Duplex Reversal Unit	81
When “Remove Misfeed A:Internal Path” Appears	82
When “Remove Misfeed B: Fusing Unit” Appears	83
When “Remove Misfeed W: Mailbox” Appears	84
When “Remove Misfeed R: Finisher” Appears.....	85
When “Remove Misfeed Y: Paper Tray” Appears	87
When “Remove Misfeed :Duplex Unit” Appears	87
Removing Misfed Paper in the Duplex Feed Unit	88
Removing Jammed Staples	91
Adding Staples	93
Removing Punch-hole Chips	95
If the message appears even after removing the Punch-hole chips	95

5. Appendix

When the Front Cover Does Not Close	97
Moving and Transporting the Printer	98
Moving the Printer	98
Consumables	100
INDEX	102

1. Replacing Consumables and Maintenance Kit

Using the Screwdriver

The screwdriver supplied is used for attaching options and is located inside the front cover. By pushing the screw top into the screwdriver, you can work without having to worry about dropping the screw.

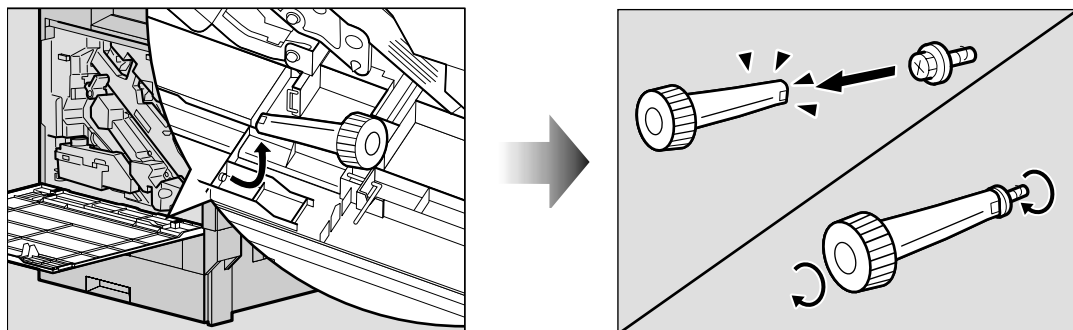

ZHXH170J

Note

- ❑ After using the screwdriver, return it to its original position inside of the front cover.

Replacing the Toner Cartridge

1

⚠ WARNING:

- **Do not incinerate spilled toner or used toner. Toner dust is flammable and will ignite when exposed to an open flame. Disposal should take place at an authorized dealer or appropriate collection site. If you dispose of used toner cartridges yourself, dispose according to local regulations.**

⚠ CAUTION:

- **Keep toner (used or unused) and the toner cartridge out of reach of children.**

📌 Note

- ❑ The actual number of printed pages differs depending on paper type, size, contents, and settings. For details, see p.100 “Toner cartridge”.

If “Add Toner” appears on the display, replace the toner cartridge.

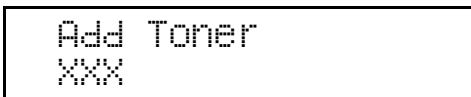

or

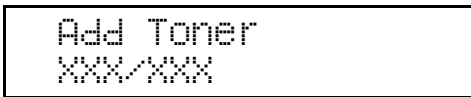

📌 Note

- ❑ A combination of one to four colors, yellow, magenta, cyan, black, appears in “XXX”.

- ❑ If cyan, magenta, or yellow toner runs out, you can print in black and white mode using the black toner. Change the color mode setting to “Black and White” from the printer driver.
- ❑ If black toner runs out, printing is not possible until the black toner cartridge is replaced.

- 1** While pushing the lock button on the upper right cover of the printer (1), open the upper right cover (2).

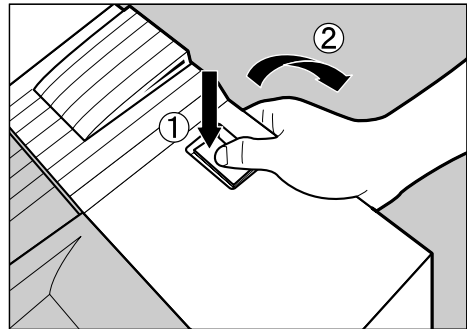

ZDJT006J

From the end, the toner cartridges are installed in the order of magenta (M), cyan (C), yellow (Y), and black (K).

- 2** Remove the toner cartridge for the color you want to replace.

- 1** Unhook the green hook on the toner cartridge with one hand.

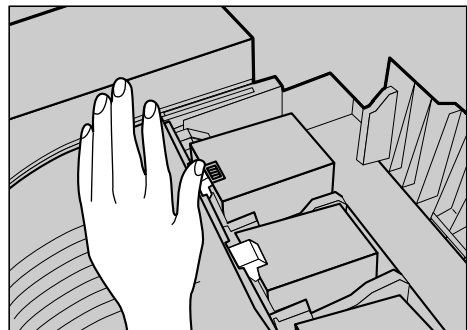

ZDJT999J

- 2** Holding the toner cartridge with the other hand, slowly pull it up and out.

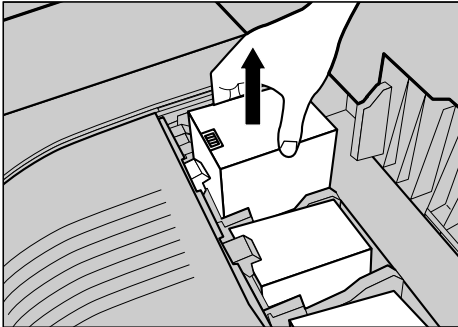

ZDJT201J

Important

- Do not shake the removed toner cartridge. Remaining toner might scatter.

Note

- Depending on the setting up environment, toner might be left in a toner cartridge. In such cases, reinstall the toner cartridge.

- 3** Take the new toner cartridge out of the box.

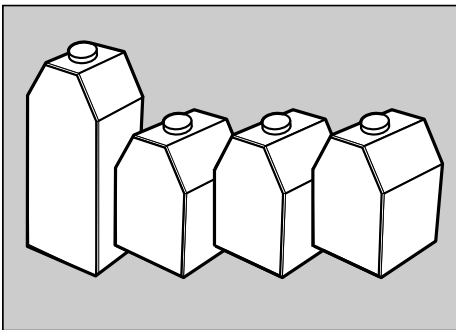

ZDJT202J

Note

- The black toner cartridge contains more than the other toner cartridges.

- 4** Shake the toner cartridge back and forth five or six times.

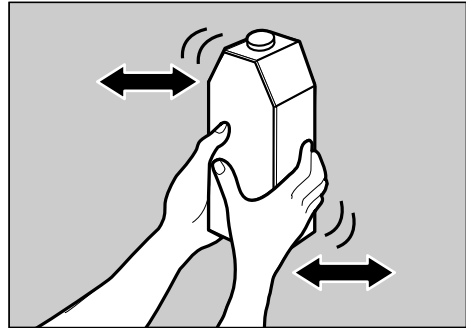

ZDJT203J

- 5** Holding the toner cartridge with the metal contact area in front, insert in the direction of the arrow.

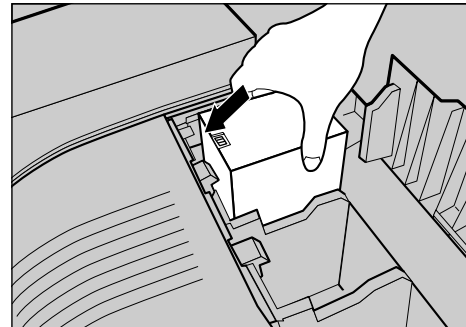

ZDJT004J

Important

- Do not touch the metal contact area with your fingers.

- 6** Slowly insert the toner cartridge, until the green hook clips over the metal contact area.

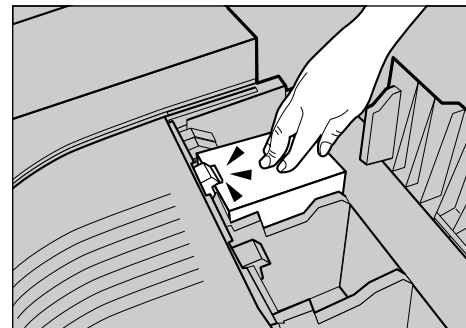

ZDJT005J

⚠ Important

- Do not install and remove toner cartridges repeatedly. This could result in toner leak.

1

7 Close the upper right cover.

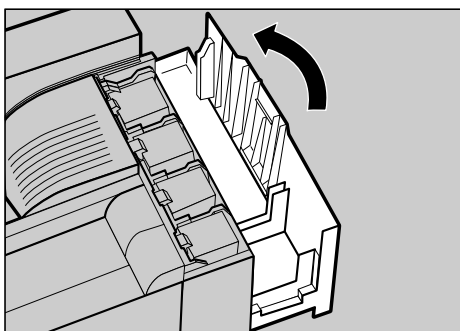

ZDJH042J

Please wait while the toner loads.

The following message appears on the display:

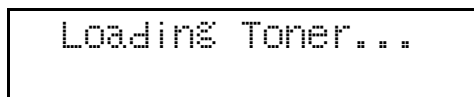

⚠ Important

- To avoid malfunction, do not turn off the power while "Loading Toner..." appears on the display.

Detaching the SR770 (2 Tray Finisher)

There are times when you may need to detach the 2 tray finisher from the printer to remove misfed paper. This section describes how to detach the 2 tray finisher.

- 1** Hold the handle at the top of the 2 tray finisher firmly using one hand, pull the 2 tray finisher straight out, and let go when it stops.

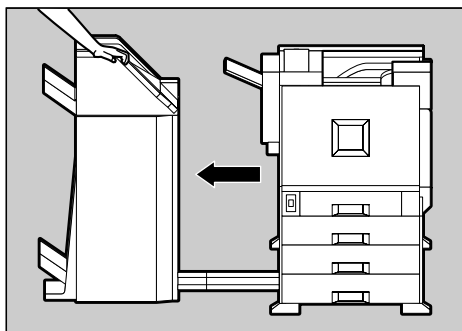

The 2 tray finisher is detached from the printer.

- 2** Use both hands to push it straight back in, and let go when it clicks into place.

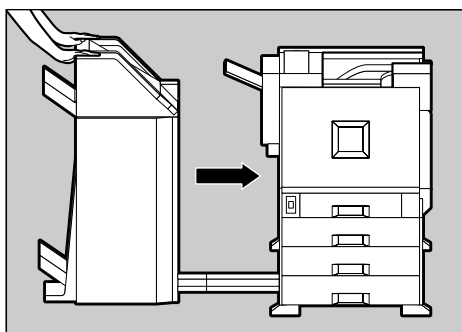

The 2 tray finisher is reattached to the printer.

Important

- Be sure to attach the 2 tray finisher to the printer after closing the duplex reversal unit. See p.6 “Opening and Closing the Duplex Reversal Unit”.

Opening and Closing the Duplex Reversal Unit

1

There are times when you may need to detach the duplex reversal unit to remove misfed paper. This section describes how to detach the duplex reversal unit.

- 1** Push up the lock release button and leave it in place.

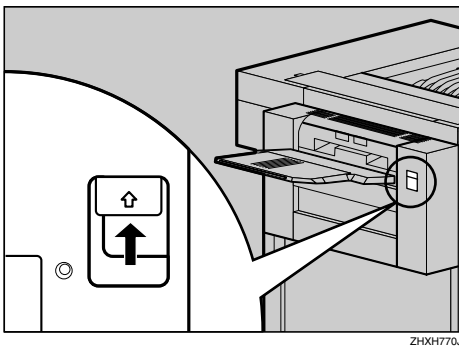

- 2** Lower the duplex reversal unit slowly until it stops.

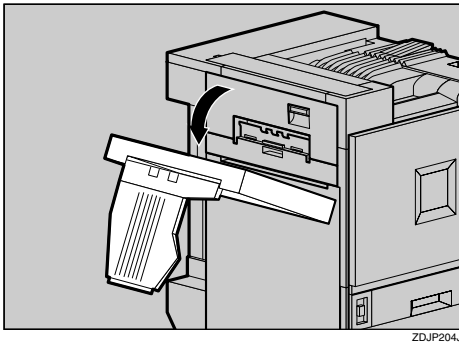

Important

- Open the duplex reversal unit after detaching the 2 tray finisher from the printer. See p.5 "Detaching the SR770 (2 Tray Finisher)".

Note

- You do not have to remove the external tray even if the 2 tray finisher is attached.

The duplex reversal unit is opened.

- 3** Close the duplex reversal unit by raising it slowly using both hands, and push it in, until it clicks into place.

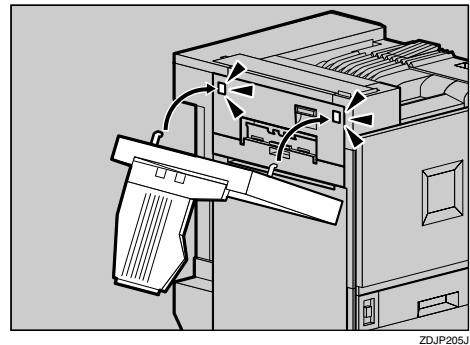

The duplex reversal unit is closed.

Important

- Attach the duplex reversal unit after closing the printer's upper left cover.

Replacing the Fuser Oil Unit

⚠ CAUTION:

- The fusing unit becomes very hot. When installing a new fuser oil unit, turn off the printer and wait about an hour. After that, install the new fuser unit. Not waiting for the unit to cool could result in a burn.
- Keep the fuser oil unit away from flames. There is a risk of fire or burns.

If “Replace Fuser Oil Unit (TypeG)” appears on the display, replace the fuser oil unit.

Replace Fuser
Oil Unit (TypeG)

- 1 Turn off the power, and then unplug the power cable.

⚡ Important

- Be sure to wait about an hour to avoid burns.

- 2 If 2 tray finisher is installed, detach it from the printer.

🔍 Reference

p.5 “Detaching the SR770 (2 Tray Finisher)”

- 3 If the duplex unit is installed, open the duplex reversal unit.

🔍 Reference

p.6 “Opening and Closing the Duplex Reversal Unit”

- 4 If the external tray is attached to the printer, raise it in the direction of the arrow (①), and then remove it (②).

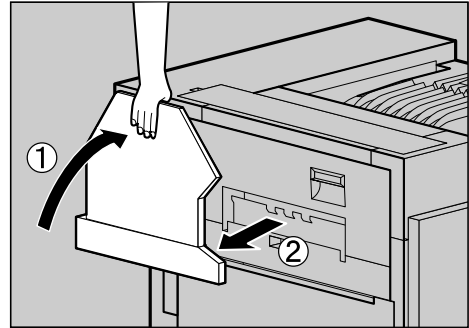

ZD-JP038J

- 5 Slowly pull out the left cover.

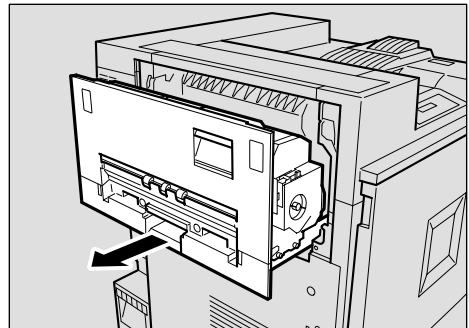

ZH-XH090J

- 6 Open the upper left cover.

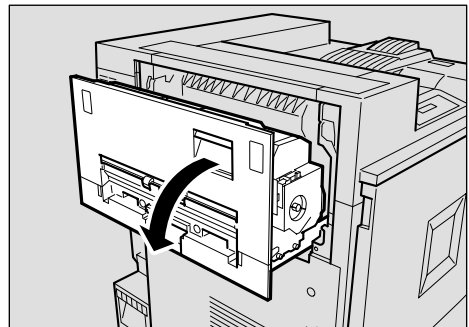

ZH-XH100J

7 Pull the lever down slightly, and then remove the grip securing the fuser oil unit.

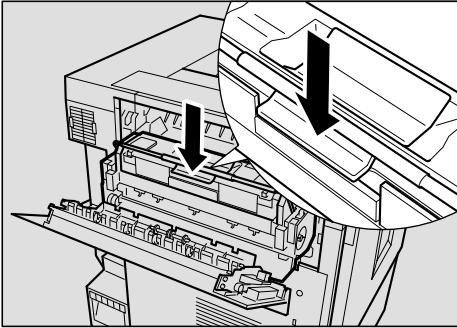

ZHXH033J

Important

- ❑ Do not touch any area other than the green felt parts.

8 Hold the fusing unit handle using one hand, and then slowly pull the fuser oil unit out horizontally. Put the unit in the bag that comes with the new fuser oil unit, and then seal the bag.

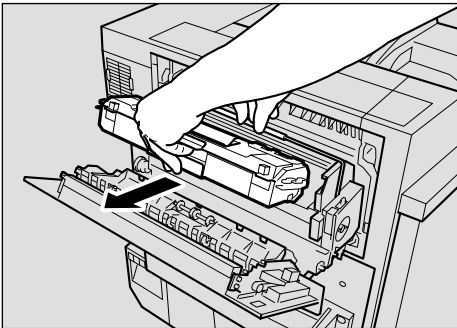

ZHXH050J

Important

- ❑ Do not touch the inside of the fusing unit.

9 Take the fuser oil unit out of the bag. Hold the green upper part of seal (1), and then slowly peel the seal off. Position the fuser oil unit as shown, and then slowly pull seal (1) out. Finally, hold the upper part of the seal (2), and then slowly peel it off.

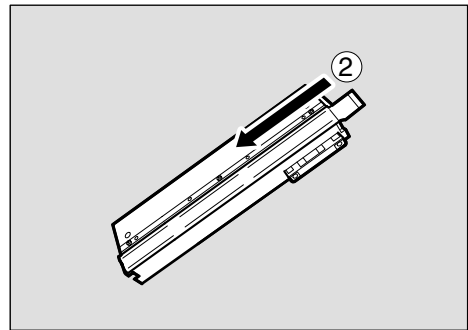
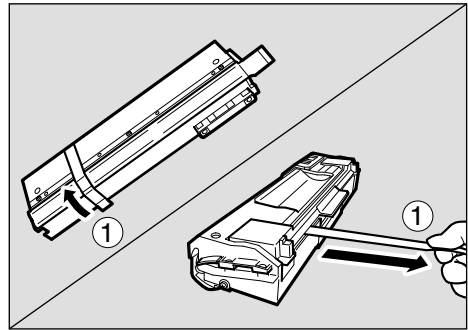

ZHXHK041J

Note

- ❑ Be sure to remove seal (1), and then pull it out horizontally.

Important

- ❑ Be sure to remove the seals to avoid malfunction.
- ❑ Be sure to remove seal (1) first, and then seal (2) to avoid oil leakage.
- ❑ Be sure to put the fuser oil unit in a stable and level place to avoid oil leakage.

- ❑ After removing the seals, be careful not to let oil from oil-supplying parts, or the seals come into contact with your body or clothes.

10 As shown, hold the fuser oil unit using one hand, hold the green handle with the other, and then slowly insert the unit horizontally, in the direction of the arrow.

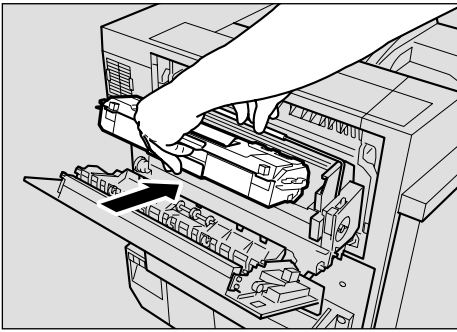

ZHXH060J

Important

- ❑ Be careful not to get oil on the top metal part of the fuser oil unit.
- ❑ Insert the fuser oil unit firmly, until it stops.

11 Slowly turn the fuser oil unit handle in the direction of the arrow, until it clicks.

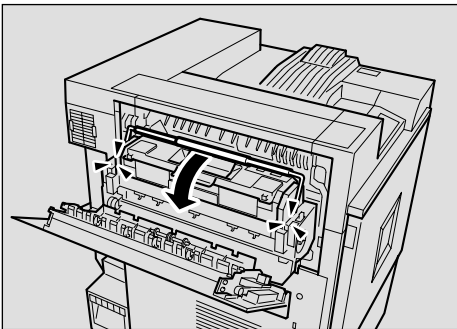

ZHXH070J

12 Close the upper left cover (1), and then push the part labeled "PUSH" next to the handle at the bottom rear, until it clicks (2).

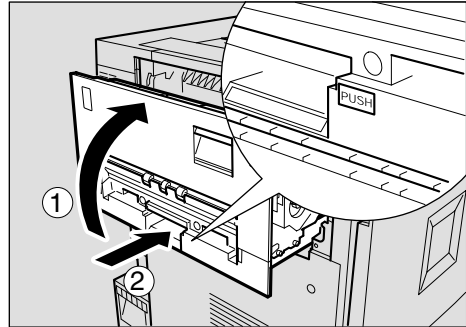

ZHXH082J

13 If you removed the external tray in step 4, reattach it to the printer. Insert the hooks of the external tray into the printer slits, and then lower it toward you.

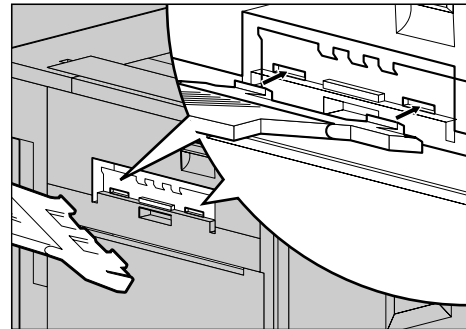

ZDJH010J

14 If the duplex unit is installed, close the duplex reversal unit.

Reference

p.6 "Opening and Closing the Duplex Reversal Unit"

15 If the 2 tray finisher is installed, reattach it to the printer.

Reference

p.5 "Detaching the SR770 (2 Tray Finisher)"

16 Plug in the power cable, and then turn on the power.

 **Note**

- If you dispose of used fuser oil unit by yourself, dispose according to local regulations.

Replacing the Photoconductor Unit

If “Replace Black PCU (Type F)” appears on the display, replace the black photoconductor unit.

Replace Black
PCU (Type F)

If “Replace Color PCU (Type A)” appears on the display, replace the three color photoconductor units.

Replace Color
PCU (Type A)

Note

- ❑ The replacement procedure for the third photoconductor unit from the top left will be described. The procedure is the same for all four photoconductor units.

- 1** Turn off the power, and then unplug the power cable.
- 2** Slowly open the front cover of the printer, remove the green screwdriver.

Reference

p.1 “Using the Screwdriver”

- 3** Turn the green lever counter-clockwise.

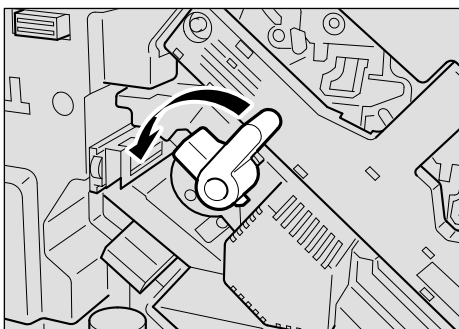

ZHXH410J

- 4** Loosen the two screws fastening the inner cover, using the provided screwdriver.

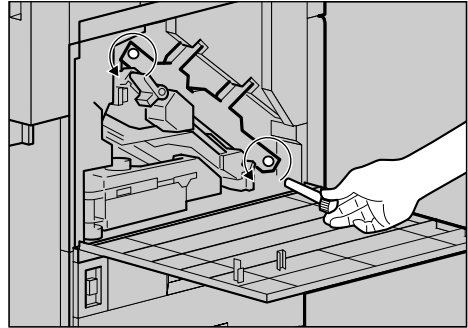

ZHXH430J

You cannot remove these two screws.

- 5** Lift the inner cover until it clicks into place and holds.

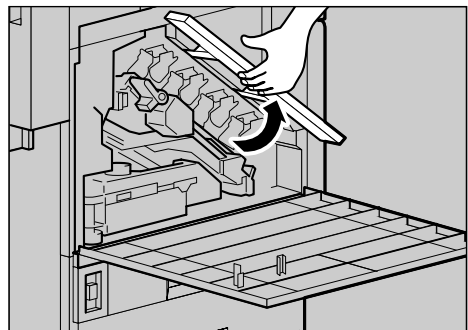

ZHXH460J

The photoconductor units are installed as shown. Starting from the upper left, the units are attached in the order of black (K), yellow (Y), cyan (C), and magenta (M).

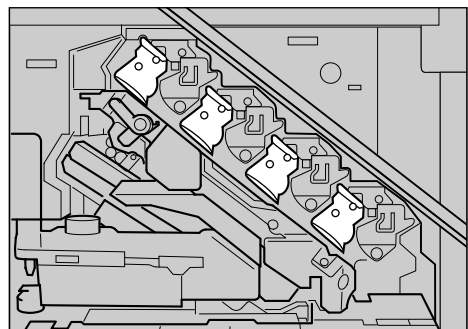

ZHXH470J

6 Remove the photoconductor unit you want to replace.

For black, remove the upper left one, and for color, remove the three on the right.

- 1** Move the green hook slowly to the right, as shown. The green hook is located on the upper right of the photoconductor unit.

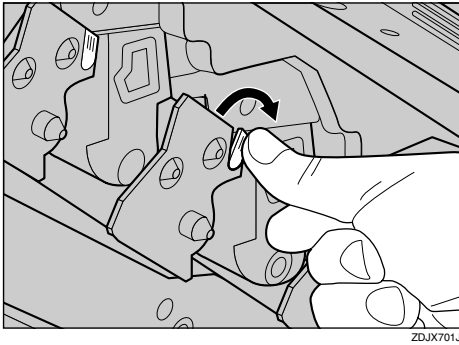

- 2** Hold the hook down, grip the green areas at the top and bottom of the photoconductor unit, and then slowly pull the unit out until you can see the entire green handle.

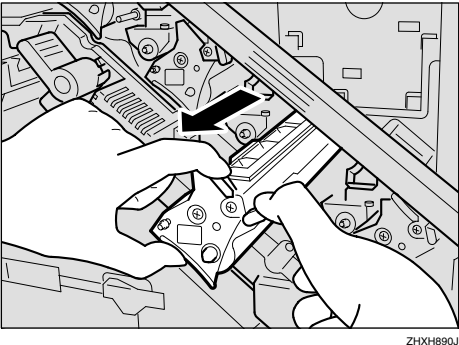

Important

- Pulling out the photoconductor unit quickly might cause it to fall.

- 3** Lift and hold the green handle at the top (1), and then slowly pull out the unit (2).

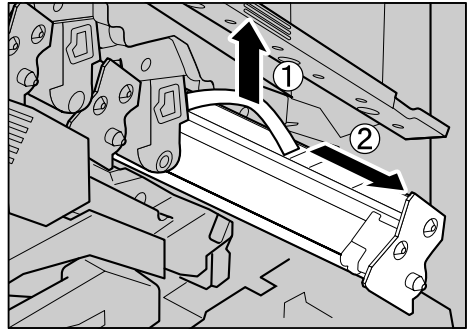

7 Install the new photoconductor unit.

For black, install one, and for color, install all three.

- 1** Take the unit out of the bag.

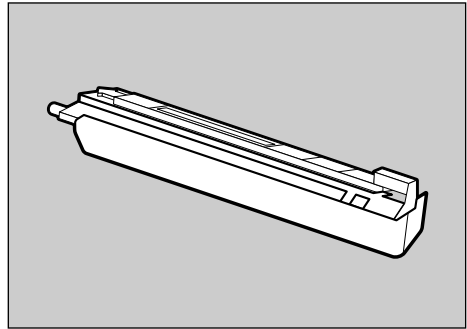

- 2** Hold the photoconductor unit, and remove the adhesive tape at the tip of the unit.

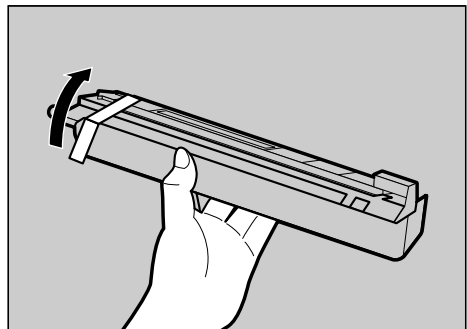

Important

- Do not remove the cover attached to the bottom of the photoconductor unit yet.

- ③ Line up the green arrow at the tip of the photoconductor unit with the rail inside the printer.

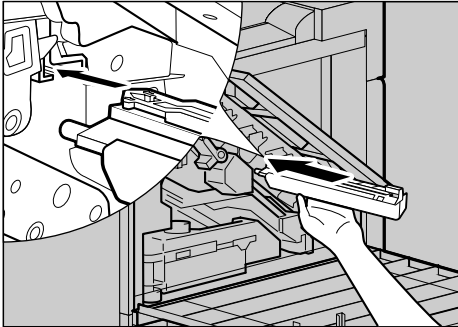

ZHXH500J

- ⑤ Remove the cover, and then slowly push in the photoconductor unit, until it stops.

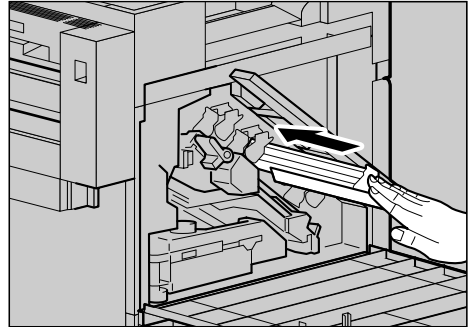

ZHXH520J

Important

- ❑ Make sure the green arrow fits securely to the rail before proceeding to the next step.

- ④ Slowly push the front of the photoconductor unit, slide the unit on the cover, and then push in until it stops.

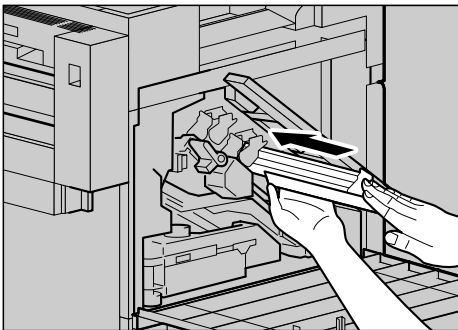

ZHXH510J

- ⑧ Slowly lower the inner cover out.

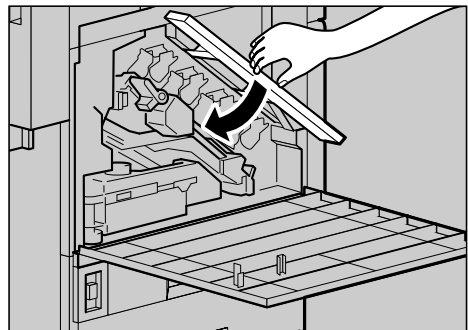

ZHXH530J

- ⑨ Tighten the two screws using the provided screwdriver.

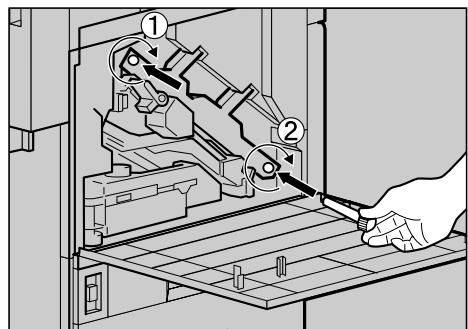

ZHXH440J

Important

- ❑ If you do not attach the green arrow of the photoconductor unit securely to the rail, you might damage the photoconductor unit.
- ❑ Do not touch the light-sensitive area of the photoconductor unit.

Note

- ❑ Be sure to return the provided screwdriver to its original position on the back of the front cover.

1

- 10 Turn the green lever clockwise.

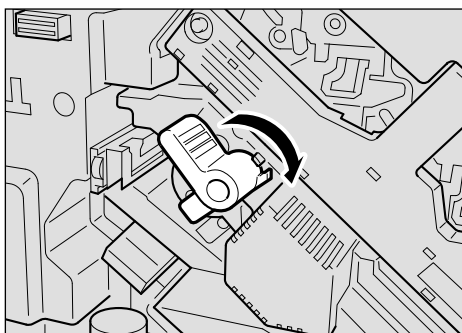

ZDXH420J

- 11 Slowly close the front cover by pushing the two areas on the left and right.

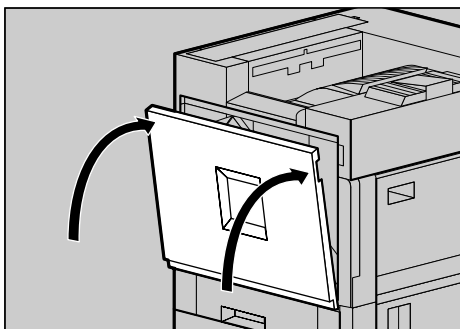

ZDJH041J

- 12 Plug in the power cable, and then turn on the power.

The printer starts calibration. Wait until it stops. The following message appears on the display:

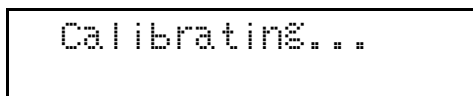

Important

- To avoid malfunction, do not turn off the power during calibration.

Replacing the Development Unit

If “Replace Black Dev. Unit(TypeD)” appears on the display, replace the black development unit.

Replace Black
Dev. Unit(TypeD)

If “Replace Color Dev. Unit(TypeB)” appears on the display, replace all three color (CMY) development units.

Replace Color
Dev. Unit(TypeB)

Note

- ❑ A dustproof filter is attached to the black development unit. When replacing the black development unit, also replace the dustproof filter. See p.22 “Replacing the Dustproof Filter”.
- ❑ When replacing the black development unit, clean the registration roller. See p.30 “Cleaning the Registration Roller”.
- ❑ The replacement procedure for the third development unit from the top left will be described. The procedure is the same for all four development units.

1 Turn off the power, and then unplug the power cable.

2 Slowly open the front cover of the printer, remove the green screwdriver.

Reference

p.1 “Using the Screwdriver”

3 Turn the green lever counter-clockwise.

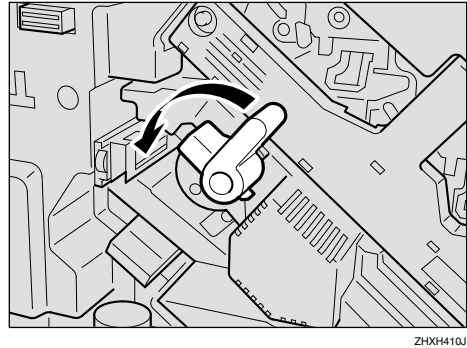

ZHXH410J

4 Loosen the two screws fastening the inner cover, using the provided screwdriver.

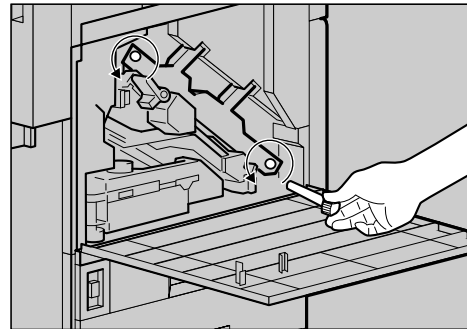

ZHXH430J

You cannot remove these two screws.

5 Lift the inner cover until it clicks into place and holds.

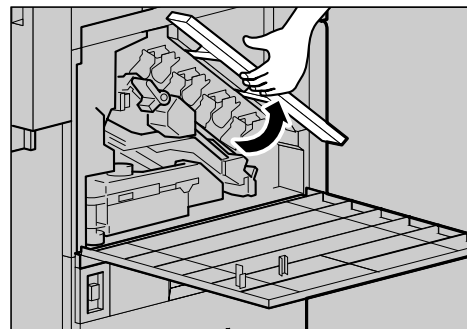

ZHXH460J

1

The development units are installed as shown. Starting from the upper left, the units are attached in the order of black (K), yellow (Y), cyan (C), and magenta (M).

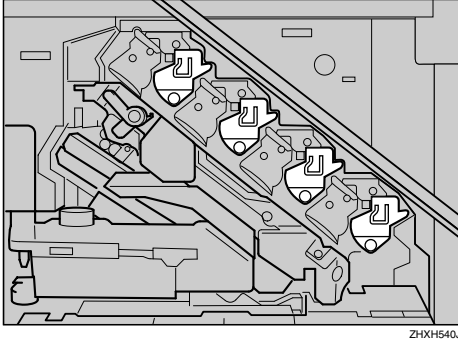

6 Remove the development unit.

The procedure for removing the unit is the same for all four colors.

- 1 Hook your finger into the green tab in front of the development unit you want to replace, and then pull it out halfway.

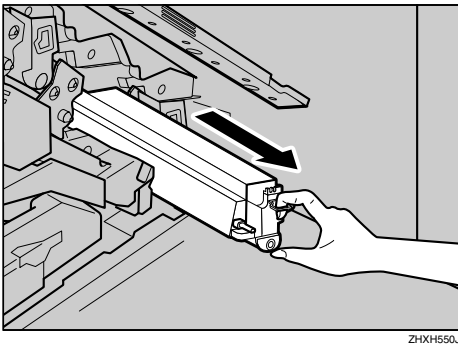

Important

- Pulling out the development unit quickly might cause it to fall.

- 2 Hold the right side of the Development unit using your right hand, and pull the unit slowly out.

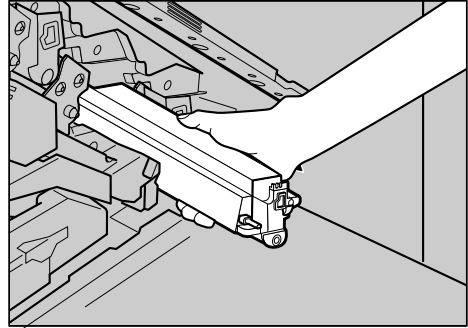

Important

- Be careful not to touch the right side of development unit.
- Be careful not to let it come into contact with your hands or clothes.

7 Install a new development unit.

The procedure for attaching the development unit is the same for all four colors.

- 1 Take the unit out of the bag.

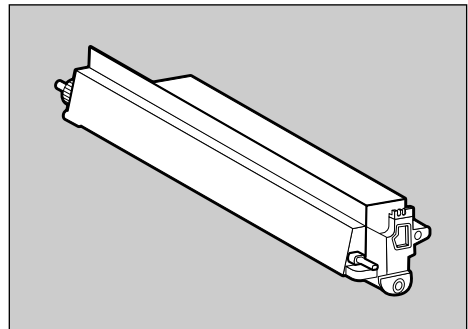

- 2** Insert the development unit along the rail, and push in slowly, until it stops.

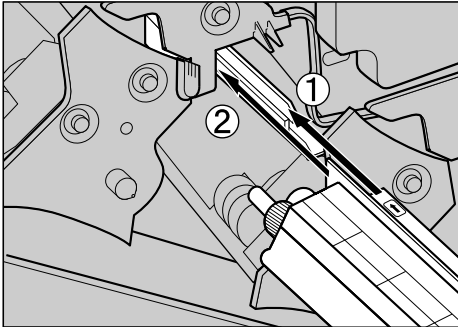

- 3** Holding the development unit, slowly pull out the tape horizontally.

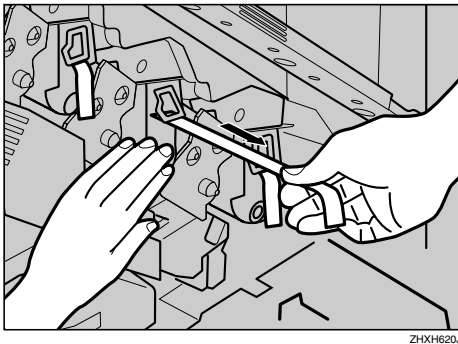

Important

- To avoid malfunction, be sure to pull out the tape.
- The removed tape is dirty. Be careful not to let it come into contact with your hands or clothes.

- 8** Slowly lower the inner cover out.

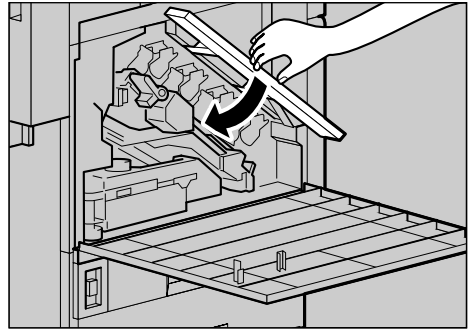

- 9** Tighten the two screws using the provided screwdriver.

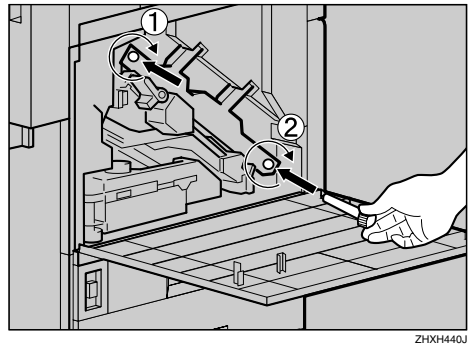

Note

- Be sure to return the provided screwdriver to its original position on the back of the front cover.

- 10** Turn the green lever clockwise.

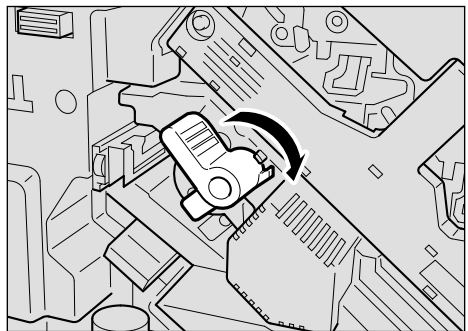

- 11** Slowly close the front cover by pushing the two areas on the left and right.

1

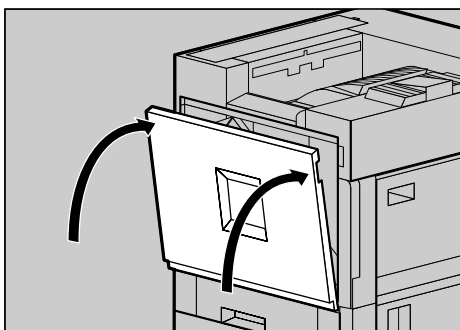

- 12** Plug in the power cable, and then turn on the power.

“Please Wait ” appears on the display, and initial adjustments begin. Wait until these stop.

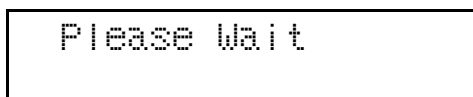

⚠ Important

- To avoid malfunction, do not turn off the power during adjustments.

Replacing the Fusing Unit

⚠ CAUTION:

- The fusing unit becomes very hot. When installing a new fuser oil unit, turn off the printer and wait about an hour. After that, install the new fuser unit. Not waiting for the unit to cool could result in a burn.
- Keep the fuser oil unit away from flames. There is a risk of fire or burns.

If “Replace Fusing Unit (Type C)” appears on the display, replace the fusing unit.

Replace Fusing
Unit (Type C)

- 1 Turn off the power, and then unplug the power cable.

⚡ Important

- Be sure to wait about an hour to avoid burns.

- 2 If the 2 tray finisher is installed, detach it from the printer.

🔍 Reference

p.5 “Detaching the SR770 (2 Tray Finisher)”

- 3 If the duplex unit is installed, open the duplex reversal unit.

🔍 Reference

p.6 “Opening and Closing the Duplex Reversal Unit”

- 4 If the external tray is attached to the printer, raise it in the direction of the arrow (①), and then remove it (②).

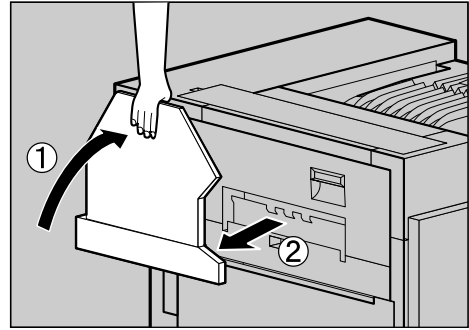

ZD.JP038J

- 5 Slowly pull out the left cover.

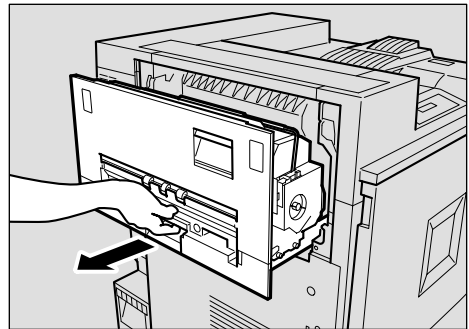

ZHXH010J

- 6 Open the upper left cover.

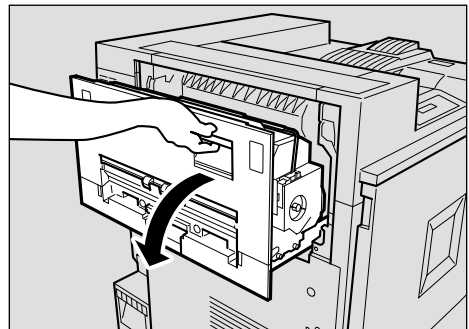

ZHXH020J

1

7 Pull the lever down slightly, and then remove the grip securing the fuser oil unit.

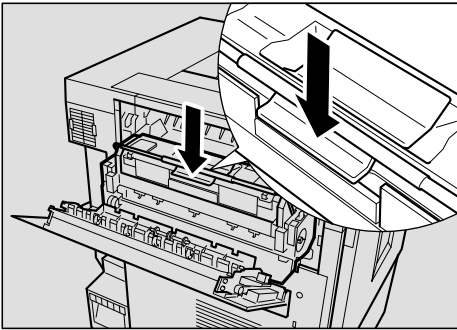

ZHXH033J

CAUTION:

- Touch only the handles, no other parts. The fuser oil unit gets very hot and will burn your hands if you touch it.

Important

- Do not touch any area other than the green felt parts.

8 Hold the fusing unit handle as shown, slowly pull the fusing unit up, and then put it down on a surface.

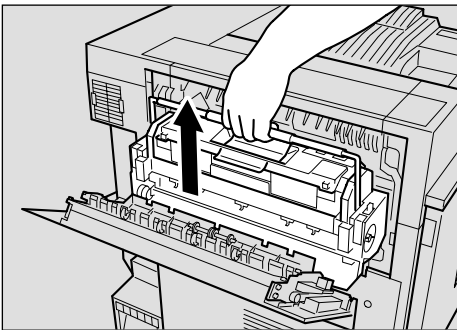

ZHXH810J

Important

- Do not touch the inside of the fusing unit.
- When moving the fusing unit, keep it steady, otherwise the fuser oil unit may come off or oil may leak.

9 Take the new fusing unit out of the bag and put it down on a level surface.

10 Pull the fuser oil unit (attached to the fusing unit) out horizontally, and then remove it.

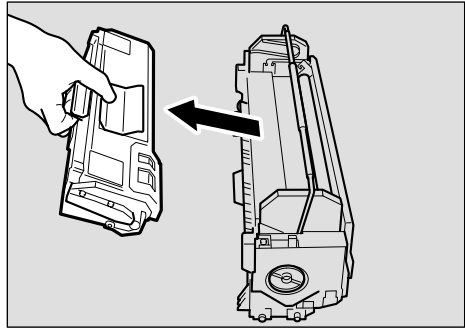

ZHXH790J

CAUTION:

- Keep the fuser oil unit away from flames. There is a risk of fire or burns.

Important

- To avoid getting oil on yourself, do not touch any areas other than the green felt parts.

11 Install the fuser oil unit removed in step 9 in the new fusing unit. Hold the fuser oil unit as shown, and then insert it horizontally into the part of the fusing unit shown below.

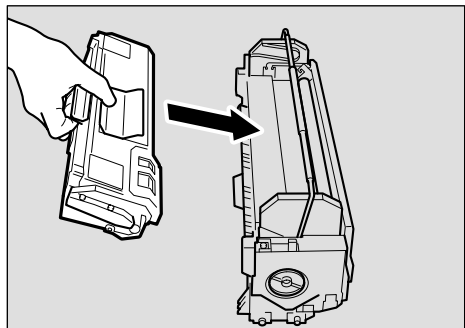

ZHXH800J

Important

- Be careful not to get oil on the top metal part of the fuser oil unit.
- Insert the fuser oil unit firmly, until it stops.

12 Put the removed fuser oil unit in the bag that enclosed the new fuser oil unit, and then seal it.

13 Hold the fusing unit handle and slowly lower the unit to align it with the marks on the machine stand.

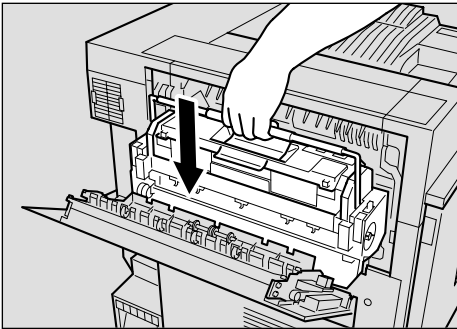

ZHXH820J

Important

- Install the fusing unit so the blue dial is on the front cover side.

14 Slowly turn the fuser oil unit handle in the direction of the arrow, until it clicks.

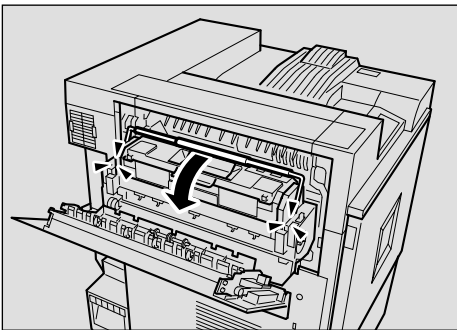

ZHXH070J

15 Close the upper left cover (1), and then push the part labeled "PUSH" next to the handle at the bottom rear, until it clicks (2).

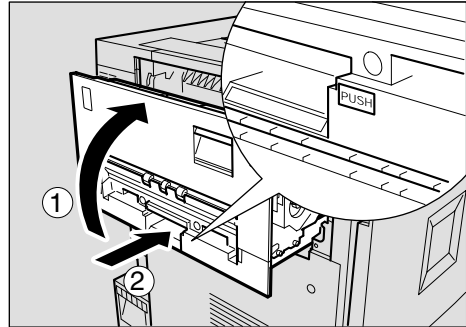

ZHXH082J

16 If you removed the external tray in step 4, reattach it to the printer. Insert the hooks of the external tray into the printer slits, and lower it toward you.

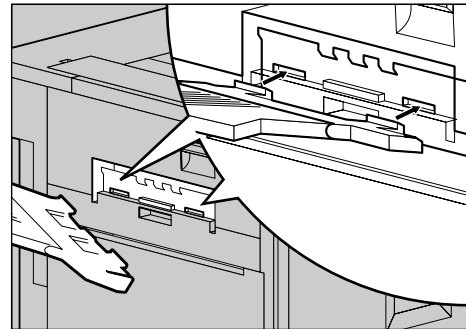

ZDJH010J

17 If the duplex unit is installed, close the duplex reversal unit.

Reference

p.6 "Opening and Closing the Duplex Reversal Unit"

18 If the 2 tray finisher is installed, reattach it to the printer.

Reference

p.5 "Detaching the SR770 (2 Tray Finisher)"

19 Plug in the power cable, and then turn on the power.

Replacing the Dustproof Filter

1

The dustproof filter is attached to the black development unit. When replacing the black development unit, also replace the dustproof filter.

The dustproof filter is attached to the left side of the printer, as shown.

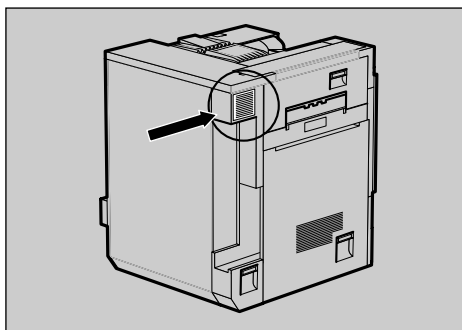

ZDJH801J

1 Turn off the power, and then unplug the power cable.

2 Push in the grips on both sides of the dustproof filter cover to pull it off.

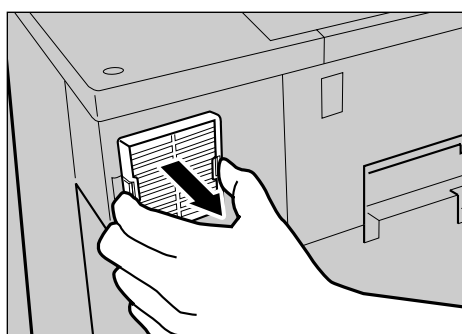

ZHXH570J

 **Note**

- Be sure to put the removed dustproof filter cover down on a stable and level surface.

3 From the box that contained the black development unit, take out the new dustproof filter and glove.

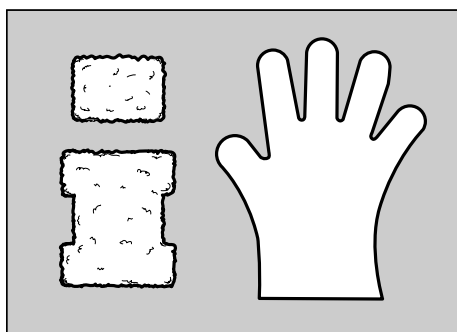

ZDJH214J

4 Put the glove on either hand.

- 5** Using your gloved hand, slowly take out the dustproof filters attached to the dustproof filter cover, one by one, and put them into the box that contained the black development unit.

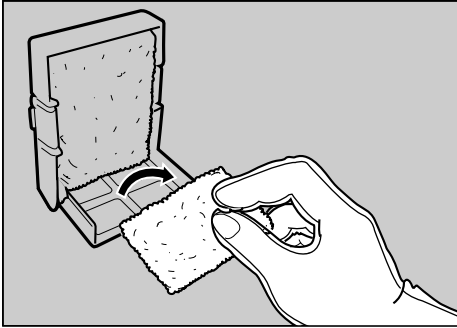

ZDJH213J

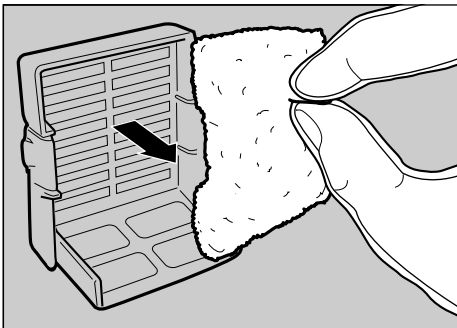

ZDJH215J

Important

- Handle the removed dustproof filters with care. If you shake them, dust might scatter.

- 6** Take off the glove.

Important

- Be sure to take off the glove before attaching a new dustproof filter.

- 7** Attach the new dustproof filters to the dustproof filter cover one by one.

- 1** Attach the large filter.

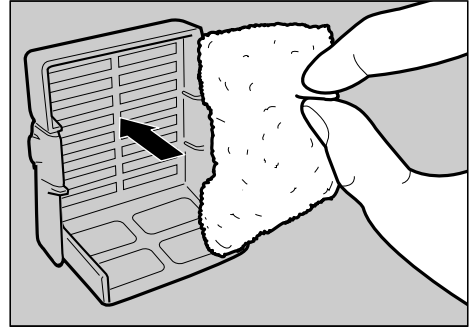

ZDJH216J

- 2** Attach the small filter.

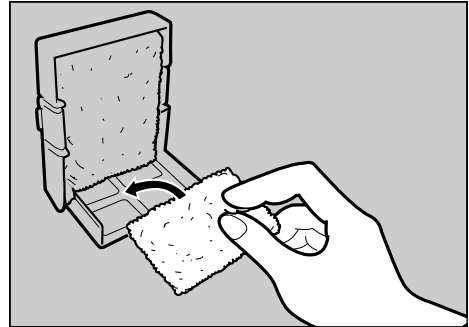

ZDJH217J

- 8** Insert the dustproof filter cover into the upper left area of the printer.

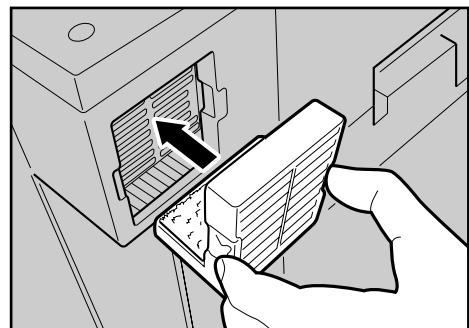

ZHXH580J

- 9** Plug in the power cable, and then turn on the power.

Replacing the Waste Toner Bottle

If “Replace Waste Toner (Type E)” appears on the display, replace the waste toner bottle.

Replace Waste
Toner (Type E)

- 1 Turn off the power, and then unplug the power cable.
- 2 Slowly open the front cover by pulling down from the two areas on the left and right.

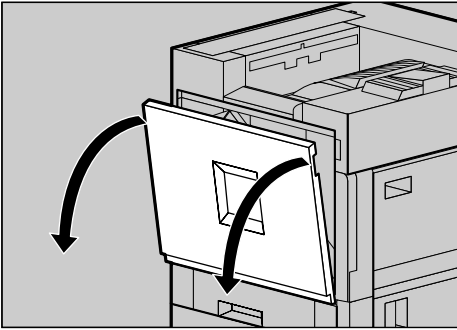

ZDJH007J

- 3 Carefully pivot the waste oil bottle outward, in the direction of the arrow.

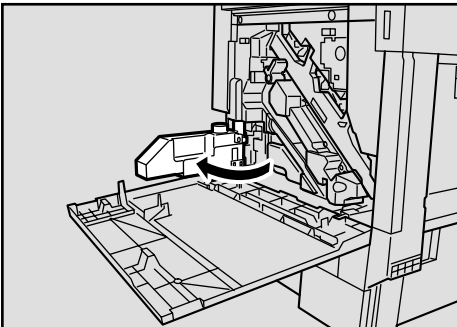

ZHXH150J

CAUTION:

- Keep the waste oil bottle away from flames. There is a risk of fire or burns.

- 4 Take the new waste toner bottle out of the bag.

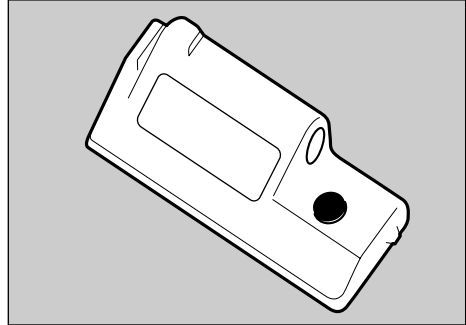

ZDJH228J

- 5 Slowly remove the used waste toner bottle from inside the printer.

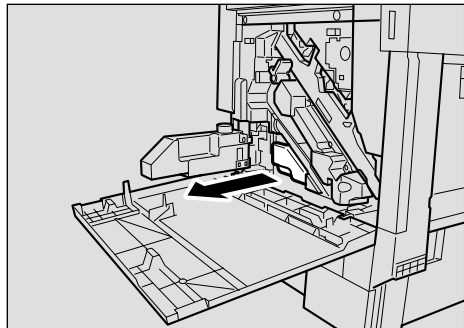

ZHXH590J

Important

- Be sure to remove the waste toner bottle horizontally.

- 6** Remove the lid (①), and then put it in the position shown in the illustration (②).

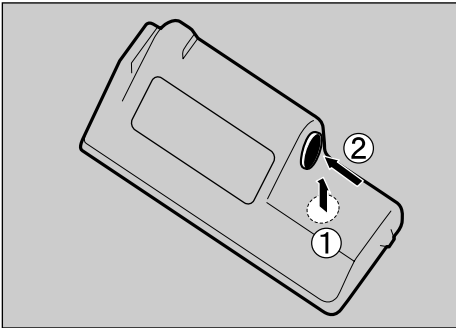

- 7** Put the used waste toner bottle into the bag that contained the new waste toner bottle, and then seal the bag.

Important

- Be sure to handle the bottle carefully so waste toner does not spill.

- 8** Insert the new waste toner bottle as shown.

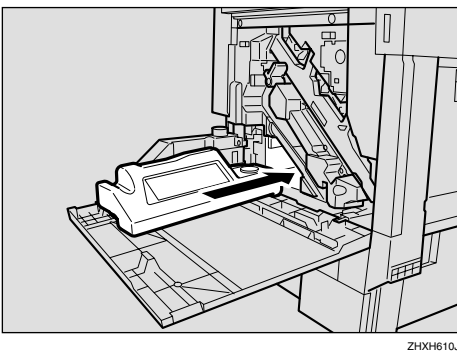

- 9** Push it in until it stops.

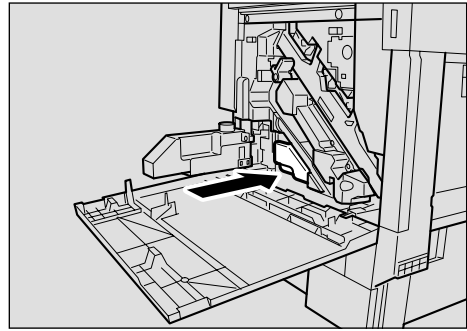

Important

- Be sure to firmly insert the waste toner bottle to avoid toner leakage inside the printer.

- 10** Slowly close the waste oil bottle in the direction of the arrow.

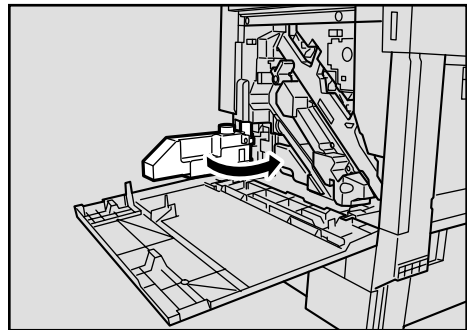

- 11** Slowly close the front cover by pushing the two areas on the left and right.

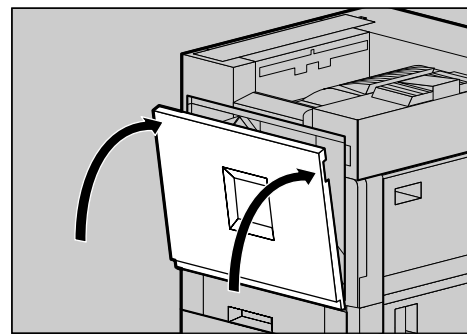

- 12** Plug in the power cable, and then turn on the power.

Replacing the Paper Feed Rollers

1

If “Replace Feed Roller (Type H)” appears on the display, replace all three feed rollers.



Note

The following illustrations are examples of replacing the paper feed rollers of Tray 1. The same procedure applies to other trays.

1 Check the contents of the box.

❖ Paper Feed Roller A

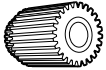

❖ Paper Feed Roller B

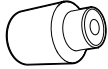

❖ Paper Feed Roller C



❖ Two Stoppers



2 Turn off the power, and then unplug the power cable and interface cable.

Important

If you are replacing the paper feed rollers of the optional 2000-sheet Large Capacity Tray, remove all paper from the tray.

3 Slowly pull out all trays while lifting up a little.

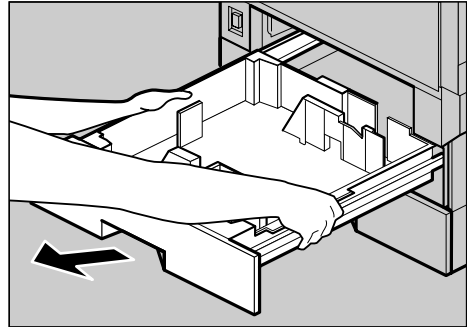

ZERH010E

Note

If you are replacing the paper feed rollers of the optional paper feed unit, or 2000-sheet Large Capacity Tray, pull out all paper trays from each unit.

4 Check the position of the paper feed rollers.

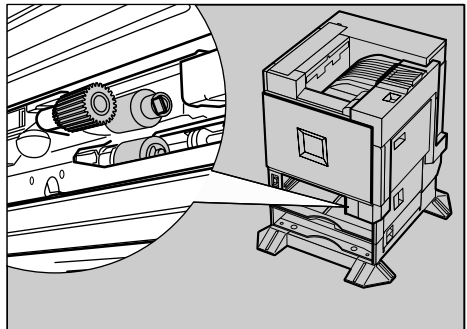

ZERH020E

Confirm the positions and names of each roller.

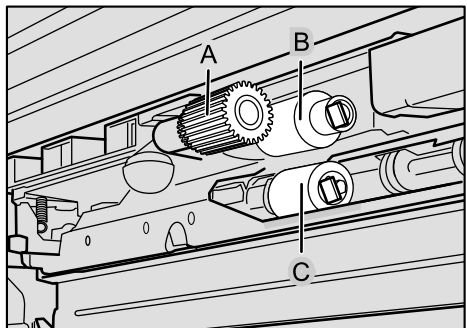

ZERH030E

- 5** While pushing the pin of paper feed roller A outwards (①), remove the paper feed roller (②).

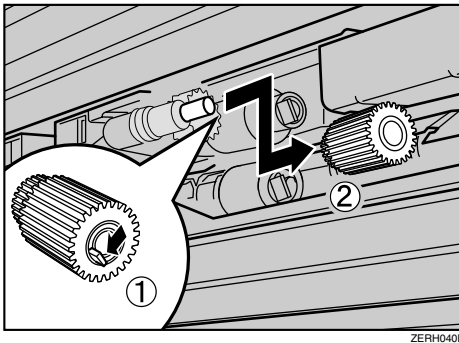

ZERH040E

- 6** Remove the stopper from paper feed roller B (①), and then remove the roller (②).

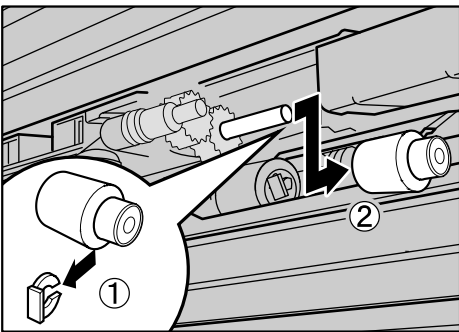

ZERH050E

- 7** Remove the stopper from paper feed roller C (①), and then remove the roller (②).

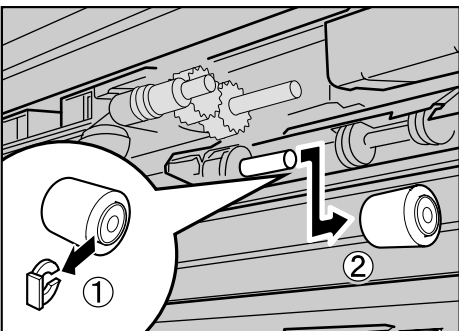

ZERH060E

- 8** Hold the new paper feed roller C with its gear towards the shaft. Insert it into the rear shaft so that the roller gear interlocks with the shaft gear (①). Lock the roller with the stopper (②).

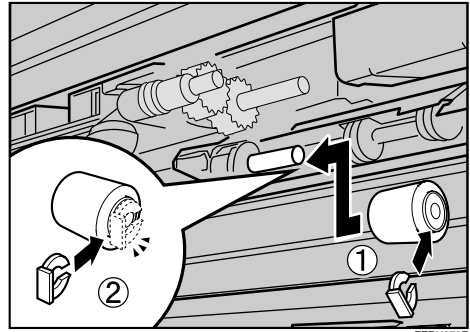

ZERH070E

- 9** Hold the new paper feed roller B with its gear towards the shaft. Insert it into the rear shaft so that the roller gear interlocks with the shaft gear (①). Lock the roller with the stopper (②).

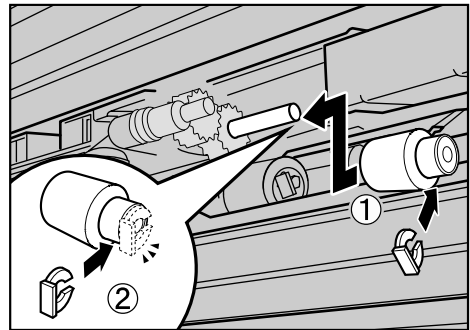

ZERH080E

- 10** Hold the new paper feed roller A with its pin towards you (①). Insert the roller onto the front shaft until it clicks into place (②).

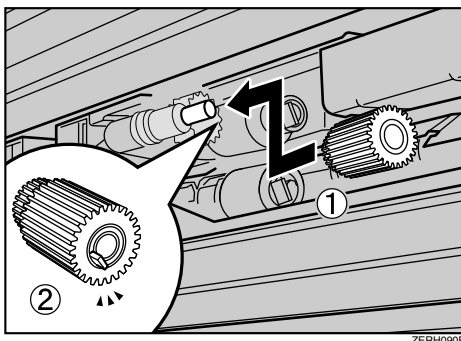

- 11** Slowly slide all trays back into the printer until they stop.

Note

- If you are replacing the paper feed rollers of the optional 2000-sheet Large Capacity Tray, load the stocks removed in step 2 into the tray.

2. Cleaning and Adjusting the Printer

Cautions to Take When Cleaning

WARNING:



- *Do not remove any covers or screws other than those specified in this manual. Some parts of the machine are at a high voltage and could give you an electric shock. Also, if the machine has laser systems, direct (or indirect) reflected eye contact with the laser beam may cause serious eye damage. When the machine needs to be checked, adjusted, or repaired, contact your service representative.*
- *Do not take apart or attempt any modifications to this machine. There is a risk of fire, electric shock, explosion or loss of sight. If the machine has laser systems, there is a risk of serious eye damage.*

CAUTION:



- *When removing misfed paper, do not touch the fusing section because it could be very hot.*

Clean the printer periodically to maintain print clarity.

Dry wipe the exterior using a soft cloth. If dry wiping is not enough, wipe using a soft, wet cloth that is well wrung out. If you still cannot remove the stain or grime, use a neutral detergent, then wipe over with a well wrung wet cloth, dry wipe, and let it dry.

Important

- To avoid deformation, discoloration, or cracking, do not use volatile chemicals, such as benzine and thinner, or spray insecticide on the printer.
- If there is dust or grime inside the printer, wipe it away using a clean, dry cloth.

Cleaning the Registration Roller

⚠ CAUTION:

- *The inside of the printer becomes very hot. To avoid burns, do not touch parts labelled “hot surface”, otherwise it could cause a burn.*

Clean the roller when replacing the black development unit.

- 1** Turn off the power, and then unplug the power cable.
- 2** Open the right cover as shown.

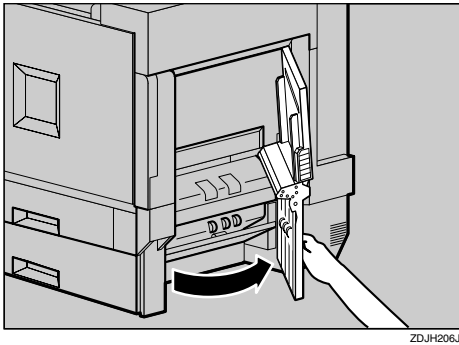

The registration roller is set as shown.

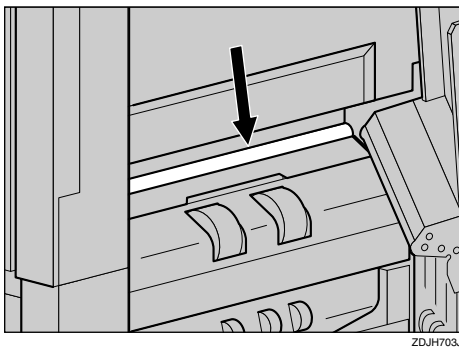

- 3** Wipe around the registration roller by turning it and applying a soft damp cloth.

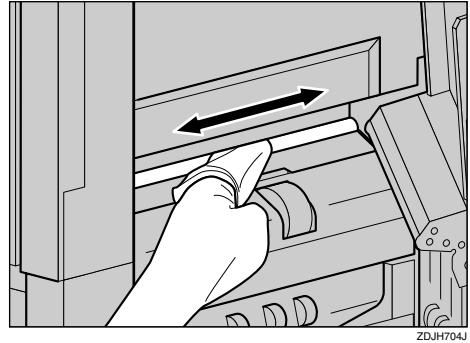

⚠ Important

- Do not use chemical cleaners or organic solvents such as thinners or benzene.

- 4** Close the right cover by pushing the area labeled “PUSH”.

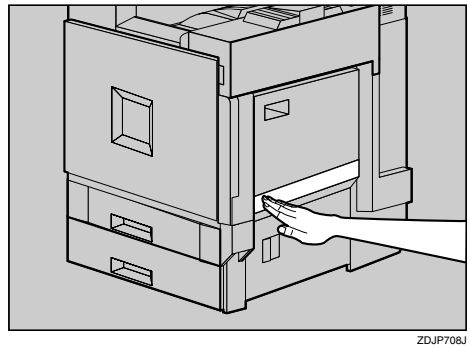

- 5** Plug in the power cable, and then turn on the power.

Cleaning the DustProof Glass

The dustproof glass may require cleaning if white lines appear on print.

1 Turn off the power, and then unplug the power cable.

2 Open the front cover, and then remove the cleaning brush.

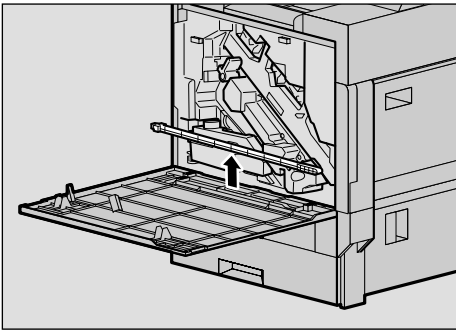

ZHXH631J

There are four holes for cleaning the dustproof glass.

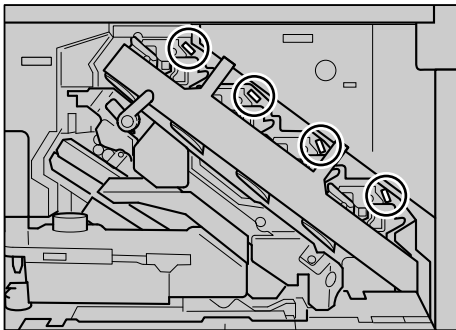

ZHXH640J

3 Slide the cleaning brush in and out slowly 8 to 10 times to clean all four areas.

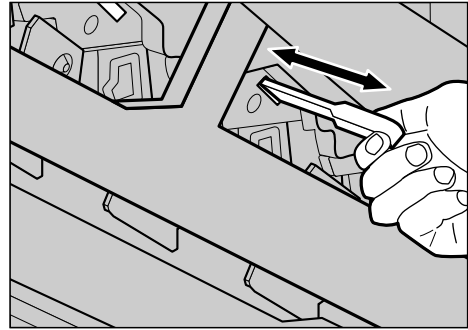

ZDJP707J

Important

- Do not insert the brush roughly. Doing so may damage the printer.

4 Return the cleaning brush to its original position.

5 Plug in the power cable, and then turn on the power.

Adjusting the Color Registration

After moving the printer, printing on thick paper, or printing repeatedly for some time, color degradation may occur. By performing color registration adjustment, you can restore optimum print quality.

2

Auto Adjust

If documents show color degradation after the printer is moved, perform automatic color adjustment.

1 Press **[Menu]**.

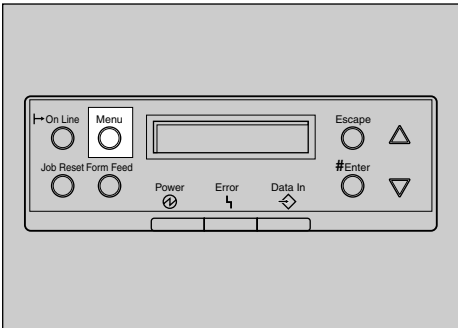

ZDJS001N

“Menu” appears on the display.

2 Press **[▲]** or **[▼]** to display “Maintenance”, and then press **[Enter #]**.



The maintenance menu appears.

3 Press **[▲]** or **[▼]** to display “Color Regist.”, and then press **[Enter #]**.



4 Confirm “Auto Adjust” appears, and then press **[Enter #]**.



5 Confirm “Now” appears, and then press **[Enter #]**.



The check message appears.



6 Press **[Enter #]**.

Automatic color adjustment begins, and the following message appears.

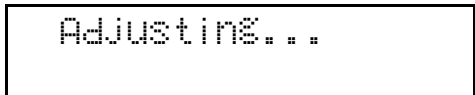

Important

- To avoid malfunction, do not turn off the power while “Adjusting...” appears on the display.

Automatic color adjustment takes about 50 seconds. A confirmation message appears when complete.

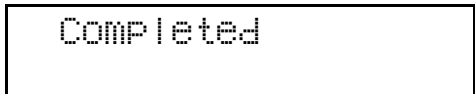

Press **[Enter #]** to return to the color adjustment menu.

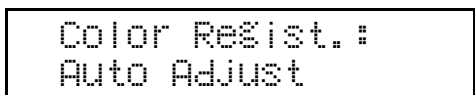

- 7** When you have made all settings, press **[On Line]**.

“Ready” appears on the display.



Adjusting the Fuser for Thick Paper

If color registration shifts when using thick paper

If color registration shifts when using thick paper, adjust the fuser for thick paper.

Note

- Fuser adjustment for thick paper is not possible if the toner has almost run out. Carry out this adjustment after changing the toner cartridge.
- Thick paper is needed to make the adjustment. Use the thick paper you normally use.

- 1** Load thick paper larger than A4  in the bypass tray.

Note

- For details about paper sizes the bypass tray can handle and paper loading procedure, see p.39 “Paper and Other Media”.

- 2** Press **[Menu]**.

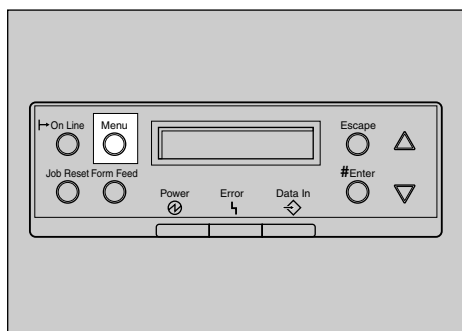

ZDJ5001N

“Menu” appears on the display.

- 3** Press **[▲]** or **[▼]** to display “Maintenance”, and then press **[Enter #]**.

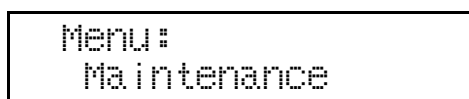

The maintenance menu appears.

- 4** Press **[▲]** or **[▼]** to display “Color Regist.”, and then press **[Enter #]**.



- 5** Press **[▲]** or **[▼]** to display “Fuser Adjust”, and then press **[Enter #]**.

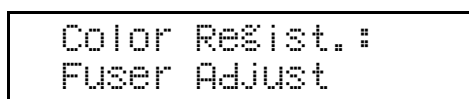

- 6** Make sure “Thick Paper” appears, and then press **[Enter #]**.

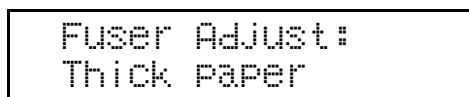

Limitation

- If the toner cartridge is almost empty, the following message appears on the display: (After changing the toner cartridge, carry out fuser adjustment for thick paper. For details about changing the toner cartridge, see p.2 “Replacing the Toner Cartridge”.)

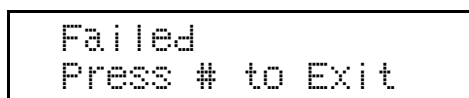

- 7** Make sure the following message appears, and then press **[Enter #]**.

```
Press #
To Adjust
```

- 8** Press **[Enter #]**.

```
Adjusting...
```

- 9** When automatic color adjustment is complete, the confirmation message about printing a test sheet appears. Wait for the following message to appear, and then click **[Enter #]**.

```
Press # for Test
Print (Bypass)
```

- 10** The following message appears:

```
Set Sheet, then#
A4(297x210)
```

Make sure the paper size set in step **3** appears, and then press **[Enter #]**.

The Fuser Adjust Sheet is printed. For test sheet samples, see p.35 "Test Sheet Samples".

Note

- In this example, thick A4 paper is loaded in the bypass tray.

- 11** Compare the color adjustment sheet sample with the framed white part of the printed pattern. If sample and printed pattern are almost the same, select "0". Otherwise, select one of the following values according to the position of the color in the sample:

Color at center: 0

Color shifted to left: -1

Color shifted to right: +1

```
Select Action:
0: Exit
```

```
Select Action:
-1: Re-adjust
```

```
Select Action:
+1: Re-adjust
```

When you select "0", the printer returns to the previous menu.

If you select "-1" or "+1", the printer returns to step **9**. Keep adjusting until you can select "0".

- 12** Press **[On Line]**.

"Ready " appears on the display.

```
Ready
```

Test Sheet Samples

The following illustration is an example of a test sheet printed during fuser adjustment for thick paper

◆ Fuser Adjust Sheet



Adjusting Image Density

Adjust image density when print becomes hazy gray or the image looks patchy.

Important

- Extreme settings may cause output to appear dirty.
- Image density settings should be made from the application or the printer driver, whenever possible.

Note

- Changing image density settings might cause deterioration in color balance. We recommend leaving image density at the factory default setting.

1 Press **[Menu]**.

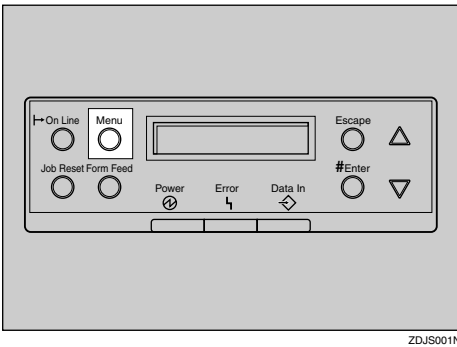

"Menu" appears on the display.

2 Press **[▲]** or **[▼]** to display "Maintenance", and then press **[Enter #]**.

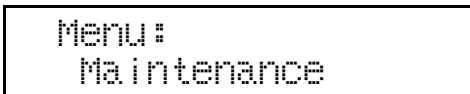

3 Press **[▲]** or **[▼]** to display "Image Density", and then press **[Enter #]**.



4 Press **[▲]** or **[▼]** to select the color you want to adjust, and then press **[Enter #]**.



5 Press **[▲]** or **[▼]** to set the image density value, and then press **[Enter #]**.

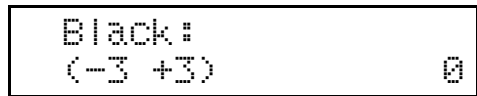

Note

- You can adjust image density in seven increments, from -3 to +3. Increasing the value makes printout darker; decreasing the value makes printout lighter.

To adjust another color, repeat steps **4** and **5**.

6 Press **[On Line]**.

"Ready " appears on the display.



Adjusting Tray Registration

You can adjust the registration of each tray. The vertical adjustment is used for all trays. Normally, you need not update the registration. But when the optional paper feed unit or the duplex unit is installed, updating is useful in some cases. The following procedure describes how to adjust Tray 3. The same procedure applies to other trays as well.

- 1 Press **[Menu]**.

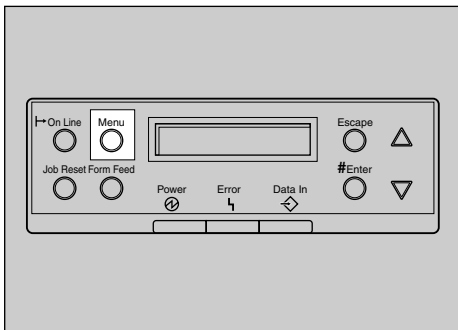

ZDJS001N

“Menu” appears on the display.

- 2 Press **[▲]** or **[▼]** to display “Maintenance”, and then press **[Enter #]**.

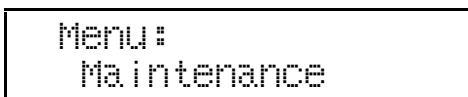

- 3 Press **[▲]** or **[▼]** to display “Registration”, and then press **[Enter #]**.

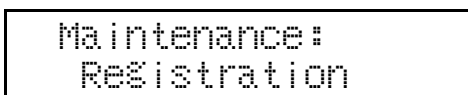

- 2 Press **[▲]** or **[▼]** to display “Adjustment”, and then press **[Enter #]**.

- 4 Print the test sheet to preview the settings.

- 1 Confirm “Test Sheet” appears, and then press **[Enter #]**.

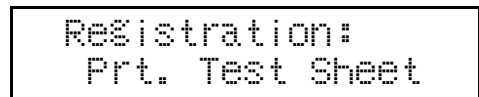

- 2 Press **[▲]** or **[▼]** to select the tray to adjust, and then press **[Enter #]**.

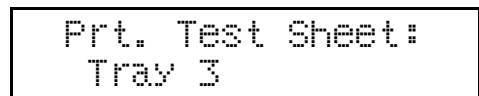

- 5 Confirm the position of the image on the test sheet, and then adjust the registration value.

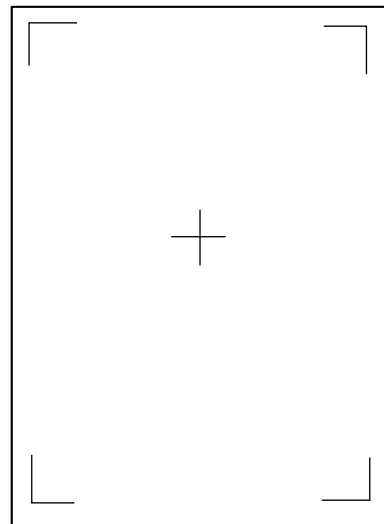

The following are examples for adjusting the margin on the test sheet:

- 1 Press **[Escape]**.

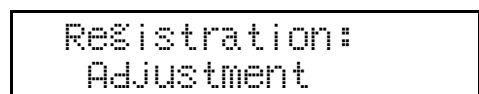

- 3 Press **[▲]** or **[▼]** to display the tray to adjust, and then press **[Enter #]**.

```
Adjustment:
Vert.: Tray 3
```

- 4 Press **[▲]** or **[▼]** to set the registration value digits (mm).

```
Vert.: Tray 3:
(-5.0 +5.0) 0
```

Note

- Increase the value to shift the print area in a positive direction; decrease to shift in a negative direction.

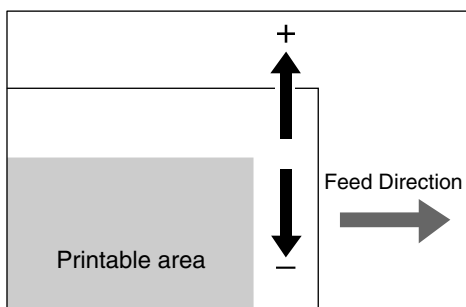

ZDJX900J

- Pressing **[▲]** or **[▼]** makes the value increase or decrease in increments of 1.0 mm.

- 5 Press **[Enter #]**.

- 6 Press **[Escape]**.

The current setting appears for 2 seconds, and then the printer returns to the previous menu.

- 6 Print the test sheet to check the settings you have made.

- 7 Press **[On Line]**.

“Ready ” appears on the display.

```
Ready
```

3. Paper and Other Media



Paper and Other Supported Media

Paper Sizes

This section describes the type, size, feed direction, and maximum amount of paper that can be loaded into each tray.











Note

- The following symbols and terminology are used to represent the feed direction.

In this manual	On the display	Paper feed direction
 ← (Feed direction)	A4 (210 × 297) 8 1/2 × 11	Short-edge feed direction
 ← (Feed direction)	A4 (297 × 210) 11 × 8 1/2	Long-edge feed direction

- Be careful of the paper feed direction. The direction is determined based on paper size.

❖ Input Paper Sizes (Metric version)

	Feed direction	Size (mm)	Bypass tray	Paper tray (Tray 1)	Paper feed unit (Tray 2/3/4)	2000-sheet Large Capacity Tray
A3		297 × 420	☆	×	⊙	×
B4 JIS		257 × 364	☆	×	⊙	×
A4		210 × 297	☆	×	⊙	×
		297 × 210	☆	●	⊙	⊙
B5 JIS		182 × 257	☆	×	☆	×
		257 × 182	☆	×	⊙	×
A5		148 × 210	☆	×	×	×
		210 × 148	☆	×	⊙	×
B6 JIS		128 × 182	★	×	×	×
A6		105 × 148	☆	×	×	×
11" × 17"		279 × 432	☆	×	⊙	×

	Feed direction	Size (mm)	Bypass tray	Paper tray (Tray 1)	Paper feed unit (Tray 2/3/4)	2000-sheet Large Capacity Tray
Legal (LG, 8 ¹ / ₂ " × 14")	☐	216 × 356	☆	×	☆	×
Letter (LT, 8 ¹ / ₂ " × 11")	☐	216 × 279	☆	×	☆	×
	☐	279 × 216	☆	×	◎	×
5 ¹ / ₂ " × 8 ¹ / ₂ "	☐	140 × 216	☆	×	×	×
Executive (Exec., 7 ¹ / ₄ " × 10 ¹ / ₂ "	☐	184 × 276	☆	×	☆	×
	☐	276 × 184	☆	×	×	×
Folio (8 ¹ / ₄ " × 13")	☐	210 × 330	☆	×	☆	×
Foolscap (F4, 8 ¹ / ₂ " × 13")	☐	216 × 330	☆	×	☆	×
F/GL (8" × 13")	☐	203 × 330	☆	×	☆	×
Com#10 Env (9 ¹ / ₂ " × 4 ¹ / ₈ "	☐	241.3 × 104.8	☆	×	×	×
C5 Env (9.02" × 6.38")	☐	229 × 162	☆	×	×	×
C6 Env (6.38" × 4.49")	☐	162 × 114	☆	×	×	×
DL Env (8.66" × 4.33")	☐	220 × 110	☆	×	×	×
Monarch Env (7 ¹ / ₂ " × 3 ⁷ / ₈ "	☐	190.5 × 98.4	☆	×	×	×
Custom Size	-	-	★*	×	×	×
8K (10 ¹ / ₂ " × 15.35")	☐	267 × 390	☆	×	☆	×
16K (7.68" × 10 ¹ / ₂ "	☐	195 × 267	☆	×	☆	×
	☐	267 × 195	☆	×	☆	×

- The size is exclusive.
- ◎ The size is supported and the printer selects it automatically.
- ☆ The size is supported, but it should be selected using the control panel.
- ★ The size is supported, but it should be set as a custom size using the control panel.
- ★* The supported size is approximately 90 - 305 mm in width, and 148 - 457 mm in length. The supported size may differ depending on the printer language you use. Set as a custom size setting using the control panel. When using the RPCS™ printer driver, sheets of up to 1260 mm in length can be set.
- ×

◆ Input Paper Sizes (Inch version)

	Feed direction	Size (inch)	Bypass tray	Paper tray (Tray 1)	Paper feed unit (Tray 2/3/4)	2000-sheet Large Capacity Tray
11" × 17"	☐	11" × 17"	☆	×	◎	×
Legal (LG)	☐	8 ¹ / ₂ " × 14"	☆	×	◎	×
Letter (LT)	☐	8 ¹ / ₂ " × 11"	☆	×	◎	×
	☐	11" × 8 ¹ / ₂ "	☆	●	◎	◎
5 ¹ / ₂ " × 8 ¹ / ₂ "	☐	5 ¹ / ₂ " × 8 ¹ / ₂ "	☆	×	×	×
Executive (Exec.)	☐	7 ¹ / ₄ " × 10 ¹ / ₂ "	☆	×	☆	×
	☐	10 ¹ / ₂ " × 7 ¹ / ₄ "	☆	×	×	×
A3	☐	11.26" × 16.54"	☆	×	◎	×
B4 JIS	☐	10.12" × 14.33"	☆	×	◎	×
A4	☐	8.26" × 5.83"	☆	×	◎	×
	☐	5.83" × 8.26"	☆	●	◎	×
B5 JIS	☐	7.17" × 10.12"	☆	×	☆	×
	☐	10.12" × 7.17"	☆	×	◎	×
A5	☐	5.83" × 8.26"	☆	×	×	×
	☐	8.26" × 5.83"	☆	×	◎	×
B6 JIS	☐	5.04" × 7.17"	★	×	×	×
A6	☐	4.13" × 5.63"	☆	×	×	×
Folio	☐	13" × 8 ¹ / ₄ "	☆	×	☆	×
Foolscap F4	☐	13" × 8 ¹ / ₂ "	☆	×	☆	×
F/GL	☐	13" × 8"	☆	×	☆	×
Com#10 Env	☐	9 ¹ / ₂ " × 4 ¹ / ₈ "	☆	×	×	×
C5 Env	☐	9.02" × 6.38"	☆	×	×	×
C6 Env	☐	6.38" × 4.49"	☆	×	×	×
DL Env	☐	8.66" × 4.33"	☆	×	×	×
Monarch Env	☐	7 ¹ / ₂ " × 3 ⁷ / ₈ "	☆	×	×	×
Custom Size	-	-	★*	×	×	×
8K	☐	10 ¹ / ₂ " × 15.35"	☆	×	☆	×
16K	☐	7.68" × 10 ¹ / ₂ "	☆	×	☆	×
	☐	10 ¹ / ₂ " × 7.68"	☆	×	☆	×









- The size is exclusive.
- ◎ The size is supported, and the printer selects it automatically.
- ☆ The size is supported, but it should be selected using the control panel.
- ★ The size is supported, but it should be set as a custom size using the control panel.
- ★* The supported size is approximately 3.5 - 12 inch in width, and 5.8 - 18 inch in length. The supported size may differ depending on the printer language you use. Set as a custom size setting using the control panel.
When using the RPCS printer driver, sheets of up to 49.6 inch in length can be set.
- × The size is not supported.

❖ Paper weight and number of sheets to be set

	Supported paper weight	Maximum number of sheets (plain paper) *1
Tray 1	60 - 105 g/m ² (16 - 28 lb)	500 (80 g/m ² , 20 lb)
Tray 2	60 - 105 g/m ² (16 - 28 lb)	500 (80 g/m ² , 20 lb)
Bypass tray	60 - 163 g/m ² (14 - 42 lb)	100 (80 g/m ² , 20 lb)
Paper Feed Unit Type 3800C (500×1)	60 - 105 g/m ² (16 - 28 lb)	500 (80 g/m ² , 20 lb)
Paper Feed Unit Type 3800C (500×2)	60 - 105 g/m ² (16 - 28 lb)	1000 (80 g/m ² , 20 lb)
Paper bank PS470 (2000-sheet Large Capacity Tray)	60 - 105 g/m ² (16 - 28 lb)	2000 (80 g/m ² , 20 lb)
SR770 (2 tray finisher)	60 - 105 g/m ² (16 - 28 lb)	2000 (80 g/m ² , 20 lb)

*1 Check that the top of the stack is not higher than the limit mark inside the tray.

❖ Output Paper Sizes (Metric version)

	Feed direction	Size (mm)	Standard tray	External tray *1	2 tray finisher	4-bin mailbox
A3		297 × 420	○	○	○	○
B4 JIS		257 × 364	○	○	○	○
A4		210 × 297	○	○	○	○
		297 × 210	○	○	○	○
B5 JIS		182 × 257	○	○	○	○
		257 × 182	○	○	○	○
A5		148 × 210	○	○	×	○
		210 × 148	○	○	○	○

	Feed direction	Size (mm)	Standard tray	External tray ^{*1}	2 tray finisher	4-bin mailbox
B6 JIS	☐	128 × 182	○	○	×	×
A6	☐	105 × 148	○	○	×	×
11" × 17"	☐	279 × 432	○	○	○	○
Legal (LG, 8 ¹ / ₂ " × 14")	☐	216 × 356	○	○	○	○
Letter (LT, 8 ¹ / ₂ " × 11")	☐	216 × 279	○	○	○	○
	☐	279 × 216	○	○	○	○
5 ¹ / ₂ " × 8 ¹ / ₂ "	☐	140 × 216	○	○	×	×
Executive (Exec., 7 ¹ / ₄ " × 10 ¹ / ₂ "	☐	184 × 276	○	○	○	○
	☐	276 × 184	○	○	×	×
Folio (8 ¹ / ₄ " × 13")	☐	210 × 330	○	○	○	×
Foolscap (F4, 8 ¹ / ₂ " × 13")	☐	216 × 330	○	○	○	×
F/GL (8" × 13")	☐	203 × 330	○	○	○	○
Com#10 Env (9 ¹ / ₂ " × 4 ¹ / ₈ "	☐	241.3 × 104.8	×	○	×	×
CA Env (9.02" × 6.38")	☐	229 × 162	×	○	×	×
C6 Env (6.38" × 4.49")	☐	162 × 114	×	○	×	×
DL Env (8.66" × 4.33")	☐	220 × 110	×	○	×	×
Monarch Env (7 ¹ / ₂ " × 3 ⁷ / ₈ "	☐	190.5 × 98.4	×	○	×	×
Custom Size	-	-	○	○	×	○
8K (10 ¹ / ₂ " × 15.35")	☐	267 × 390	○	○	○	×
16K (7.68" × 10 ¹ / ₂ "	☐	195 × 267	○	○	○	○
	☐	267 × 195	○	○	○	○

- ○ The size is supported.
- × The size is not supported.

^{*1} The external tray does not support duplex printing.

Paper Recommendations

Loading Paper

Important

- Do not use ink-jet printer paper because it may stick to the fusing unit and cause a paper misfeed.
- When printing on OHP transparencies that have a print side, load them with the print side over on the bypass tray. Not taking this precaution may cause them to stick to the fusing unit and cause misfeeds.
- Print quality cannot be guaranteed if recommended paper is not used. For details about recommended paper, contact your sales or service representative.
- Do not use paper that has already been printed onto by other printers.

Storing Paper

- Paper should always be stored properly. Improperly storing paper might result in poor print quality, paper misfeeds, or printer damage. Recommendations are as follows:
 - Avoid storing paper in humid areas.
 - Avoid exposing paper to direct sunlight.
 - Store paper on a flat surface.
- Keep open reams of paper in the packaging it came in.

Types of Paper and Other Media

❖ Plain Paper

- Tray 1/2 can hold up to 500 sheets.
Paper Feed Unit Type 3800C (500×1) can hold up to 500 sheets.
Paper Feed Unit Type 3800C (500×2) can hold up to 1000 sheets.
Paper Bank PS470 can hold up to 2000 sheets.
Check that the top of the stack is not higher than the limit mark inside the tray.
- The bypass tray can accommodate sheets 90-305 mm wide and 148-457 mm long. However, the paper size must be set using the control panel. When using the RPCS printer driver, sheets of up to 1260 mm in length can be set.
- When printing on the reverse side of plain paper that is already printed on, you should load it on the bypass tray and select **[Plain (Duplex Backside)]** from **[Paper Type:]** using the printer driver.

❖ **Thick Paper**

- Use the bypass tray
- The bypass tray can hold up to 135 kg (163 g/m²) of paper weight. Print quality on thicker paper cannot be guaranteed.
- Check that the top of the stack is not higher than the limit mark inside the tray.
- When printing on thick paper, select thick paper mode using the printer driver.
- When printing on the reverse side of plain paper that is already printed on, you should load it on the bypass tray and select **[Thick (Duplex Backside)]** from **[Paper Type:]** using the printer driver.

 **Note**

- ❑ The number of sheets that can be set may vary depending on paper thickness and type.

❖ **OHP transparencies**

- When printing on OHP transparencies, use the bypass tray.
- Load OHP transparencies on the tray with the print side over, otherwise they may stick to the fusing unit and cause a misfeed.
- Remove unused OHP transparencies from the bypass tray after you are finished printing. They may stick together if left in the tray.
- When printing on OHP transparencies, you should select the OHP transparency mode using the printer driver.
- Check that the top of the stack is not higher than the limit mark inside the tray.
- When printing multiple OHP transparencies, remove each sheet from the tray one by one before the next is printed out, or select **[Slip Sheet]** in the printer driver. For details about using “Slip Sheet”, see the printer driver Help.

❖ **Envelopes**

 **Important**

- ❑ Only envelopes ① and ② as shown below are supported.

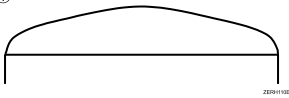
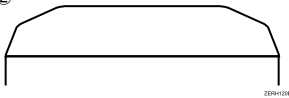
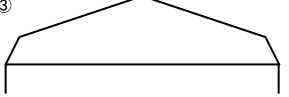
	Supported *1
	Supported *1
	Not supported

*1 Misfeeds might also occur when using envelopes ① and ② depending on the length and shape of the flaps.

- When printing on envelopes, use the bypass tray, and select **[Thick Paper]** as the paper type on the Paper Input menu on the control panel. See p.59 “Specifying a paper type for the Bypass Tray”.
- Specifications for envelopes are as follows:

	Metric version	Inch version
Weight	72 - 90 g/m ²	19 - 24 lb
Recommended weight and size	72 g/m ² , 114 × 162 mm (C6 Env)	24 lb, 3 ⁷ / ₈ ” × 7 ¹ / ₂ ” (Monarch)

- You can load up to 10 envelopes (72 - 92 g/m², 19 - 24 lb) in the bypass tray at the same time, without compressing them. Check the envelopes are not damp, and the top of the stack is not higher than the limit mark on the side guide.
- Check the print side is facing up when loading onto the bypass tray.
- When loading envelopes, be sure to unfold the flaps and position them opposite to the paper feed direction.

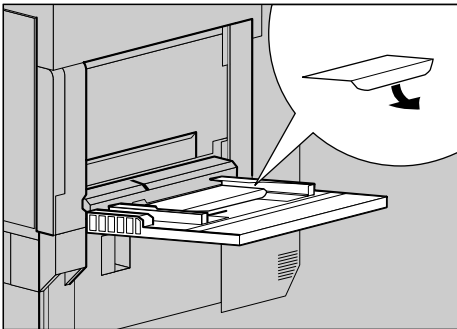

ZGBH020N

- Make the printer driver setting for rotating the print image by 180 degrees. For details, see the printer driver Help.
- Check there is no air in the envelopes before loading.
- To get better print quality, it is recommended that you set the right, left, top, and bottom print margin, to at least 15 mm (0.6”) each.
- Do not print on both sides of envelopes.
- Load only one size and type of envelope at a time.
- Before loading envelopes, flatten leading edges (the side going into the printer) by pressing a pencil or ruler across them.
- Before loading envelopes, check they are rectangular in shape.
- Supported sizes for envelopes are listed on p.39 “Paper and Other Media”.

❖ **Paper not supported by this printer**

Avoid using the following unsupported types of paper:

- Ink-jet printer paper
- Bent, folded, or creased paper
- Curled or twisted paper
- Torn paper
- Wrinkled paper
- Damp paper
- Paper that is dry enough to emit static electricity
- Paper that has already been printed onto, except a preprinted letterhead paper
- Coated paper
- Special paper, such as thermal paper, aluminum foil, carbon paper, and conductive paper
- Paper whose weight is heavier or lighter than the limitation
- Paper with windows, holes, perforations, cutouts, or embossing
- Label paper on which glue or base paper is exposed
- Paper with clips or staples

Printable Area

The following illustration shows the printable area for this printer. Be sure to set the print margins correctly using your application.

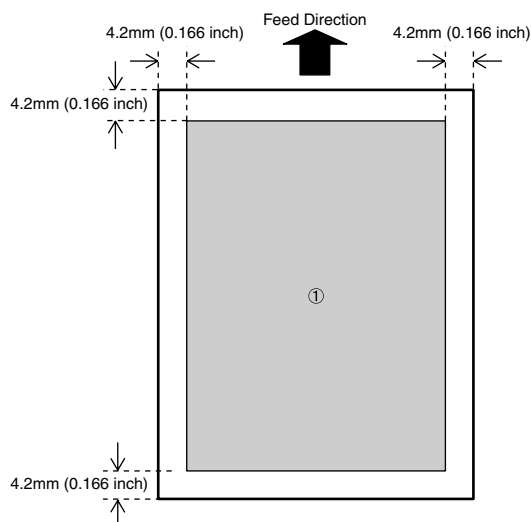

① : printable area



Note

- Printable area may vary depending on paper size, printer language, and printer driver settings.
- If you load paper larger than A3 in the bypass tray, hold it steady so it feeds properly. Paper feed accuracy and print quality may vary according to paper thickness and width. Do a test print to check the paper you want to use gives satisfactory results.
- The maximum length of the printable area is 457 mm in the paper feed direction (at 1200×1200 dpi).

Loading Paper

Load paper and change the paper size in Tray 1, Tray 2, and the optional paper feed unit by following the procedures below.

Important

- ❑ Tray 1 uses only 11 × 8 1/2  paper exclusively. Load 11 × 8 1/2 paper at all times.
- ❑ The 2000-sheet Large Capacity Tray uses only 11 × 8 1/2  paper exclusively. Load 11 × 8 1/2 paper at all times.
- ❑ If you want to load A4  paper in Tray 1 and the optional 2000-sheet Large Capacity Tray, contact your sales or service representative.



Reference

p.39 “Paper Sizes” for details about paper to be loaded in the paper tray and optional paper feed unit.

3

Loading Paper in Tray 1

Important

- ❑ Tray 1 uses only 11 × 8 1/2  paper exclusively. Load 11 × 8 1/2 paper at all times.
- ❑ If you want to load A4  paper in Tray 1, contact your sales or service representative.

1 Slowly pull out the paper tray, until it stops.

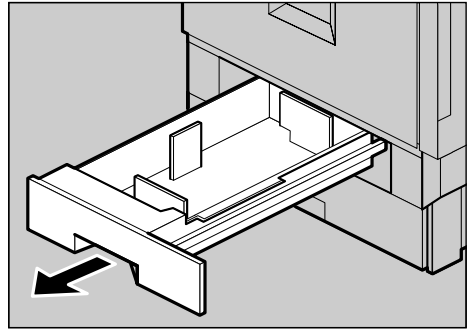

ZDJH003J

2 Load paper into the tray with the print side down.

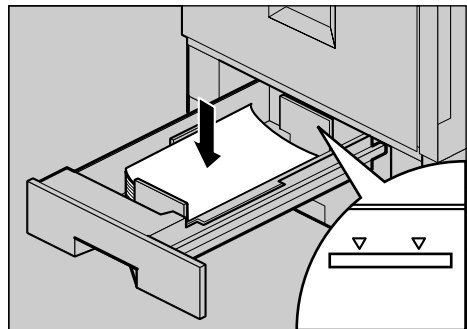

ZDJY001J

Important

- ❑ Check that the top of the stack is not higher than the limit mark inside the tray.

3 Carefully slide the paper tray into the printer, until it stops.

Loading Paper in Tray 2 and the Optional Paper Feed Unit

Paper of different sizes can be loaded in Tray 2 (standard) and the 500- and 1000-sheet paper feed units (optional) by adjusting the positions of the side and end guides.

This section describes loading paper in Tray 2 (standard).

Note

- If the side and end guides are in the right positions for the paper to be loaded, they do not have to be adjusted.

- 1** Slowly slide the paper tray out, until it stops.

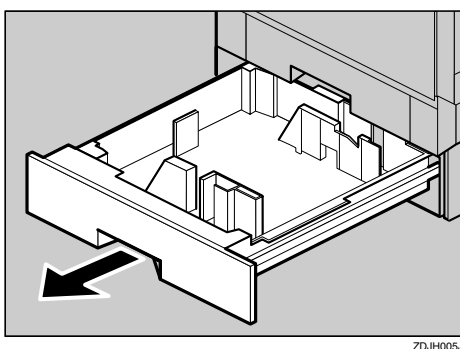

ZDJH005J

- 2** Adjust the side guide according to the size and orientation of the paper as follows:

- 1** Release the side guide lock.

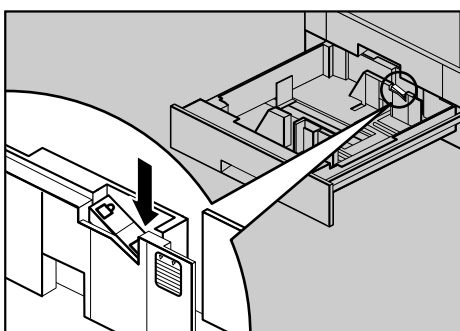

ZDJY003J

- 2** Press the side guide green lever (1), adjust the position of the guide by moving it in the direction of the arrow (2).

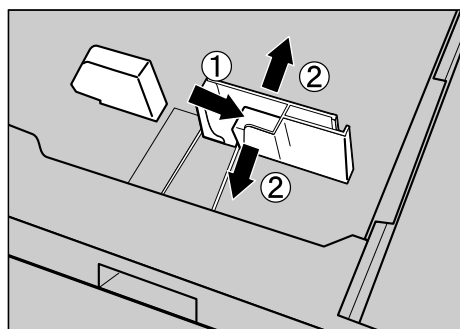

ZDJY802J

- 3** Adjust the end guide according to the size and orientation of the paper by gripping both edges of the guide (1), and then moving it in the direction of the arrow (2).

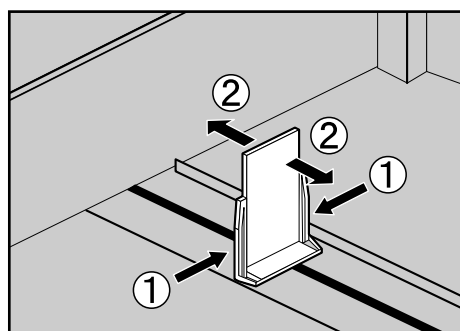

ZHxH760J

- 4** Align all four sides of the paper stack, and then load it in the tray.

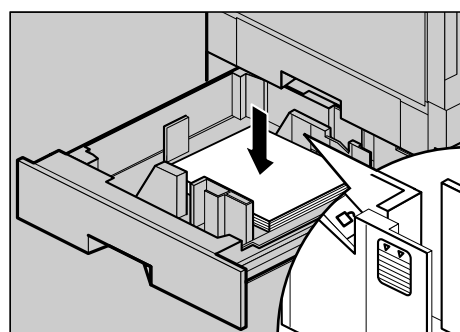

ZDJY901J

Important

- Check that the top of the stack is not higher than the limit mark inside the tray.

- 5** Make sure the paper is fixed in place, and then lock the side guide.

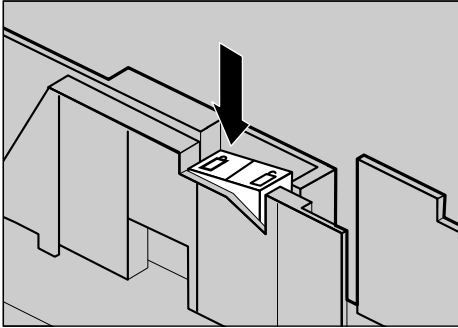

- 6** Slowly slide the paper tray back until it stops.

Important

- Do not slide the paper tray in with force. If you do, the front and side guides might move.
- Be sure to adjust the side guides to the paper size, or misfeeds might occur.

Loading paper in Paper Bank PS470 (2000-sheet Large Capacity Tray)

Important

- The 2000-sheet Large Capacity Tray uses only 11 × 8 1/2" paper exclusively. Load 11 × 8 1/2" paper at all times.
- If you want to load A4 paper in the 2000-sheet Large Capacity Tray, contact your sales or service representative.

- 1** Slowly pull out the paper tray, until it stops.

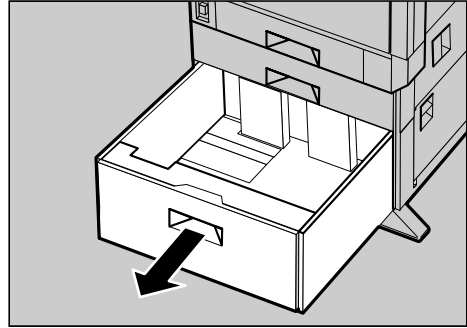

- 2** With the print side down, align all four sides of the two paper stacks, and then load them next to each other in the tray. Each side has a limit of 1,000 sheets.

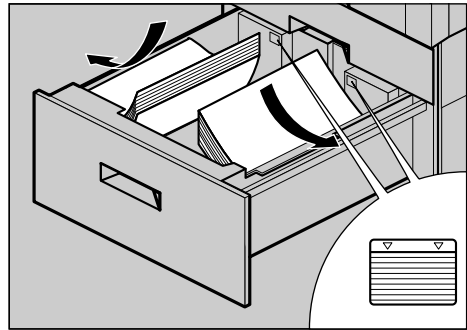

Important

- Align the paper and load the stacks against the left and right walls, or misfeeds might occur.
- Check that the top of the stack is not higher than the limit mark inside the tray.

- 3** Slowly push in the paper tray until it stops.

If you load a paper size that is not selected automatically

Note

- Paper sizes not selected automatically are B4, A4, B5, $7\frac{1}{4} \times 10\frac{1}{2}$, 8×13 , $8\frac{1}{2} \times 13$, $8\frac{1}{4} \times 13$, 8K ($10\frac{1}{2} \times 15.35$), 16K ($7.68 \times 10\frac{1}{2}$), 16K ($10\frac{1}{2} \times 7.68$).

Reference

p.51 “Loading Paper in Tray 2 and the Optional Paper Feed Unit” for details about how to load the paper

Important

- Tray 1 uses only $11 \times 8\frac{1}{2}$ paper exclusively. Load $11 \times 8\frac{1}{2}$ paper at all times.
- Paper Bank PS470 uses only $11 \times 8\frac{1}{2}$ paper exclusively. Load $11 \times 8\frac{1}{2}$ paper at all times.
- If you want to load A4 paper in Tray 1 and the optional Paper Bank PS470, contact your sales or service representative.

This section uses Letter ($8\frac{1}{2} \times 11$) as an example.

- Press **[Menu]**.

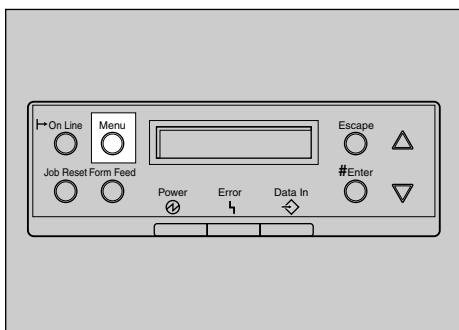

ZDJS001N

“Menu” appears on the display.

- Press **[▲]** or **[▼]** to display “Paper Input”, and then press **[Enter #]**.

```
Menu:
Paper Input
```

The paper selection menu appears.

- Press **[▲]** or **[▼]** to display “Tray Paper Size”, and then press **[Enter #]**.

```
Paper Input:
Tray Paper Size
```

The paper tray selection menu appears.

- Press **[▲]** or **[▼]** to display the target paper tray, and then press **[Enter #]**.

```
Tray Paper Size:
Tray 2
```

The paper size selection menu appears.

- Press **[▲]** or **[▼]** to display the loaded paper size, and then press **[Enter #]**.

```
Tray 2 :
8 1/2 x 11
```

After about two seconds, the display returns to the menu.

6 Press **[On Line]**.

“Ready ” appears on the display.



This completes the setting change.

Important

- ❑ After printing on a paper size that is not selected automatically, if you want to print on paper that is selected automatically again, reload the paper, proceed to step **7**, and return the setting to “Auto”.

7 Press **[Menu]**.

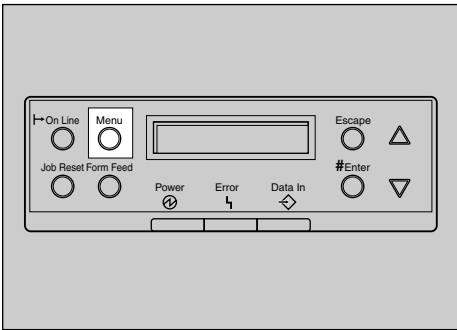

ZDJS001N

“Menu” appears on the display.

8 Press **[▲]** or **[▼]** to display “Paper Input”, and then press **[Enter #]**.

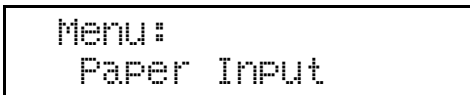

The paper selection menu appears.

9 Press **[▲]** or **[▼]** to display “Tray Paper Size”, and then press **[Enter #]**.



The paper tray selection menu appears.

10 Press **[▲]** or **[▼]** to display the target paper tray, and then press **[Enter #]**.



The paper size selection menu appears.

11 Press **[▲]** or **[▼]** to display “*Auto”, and then press **[Enter #]**.

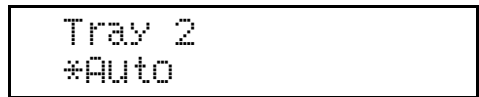

After about two seconds, the display returns to the menu.

12 Press **[On Line]**.

“Ready ” appears on the display.



Changing the paper type

By selecting the paper type you want to load, the printer performs better. You can select from the following paper types:

- Plain Paper, Recycled Paper, Special Paper, Color Paper, Letterhead, Preprinted Paper

1 Press **[Menu]**.

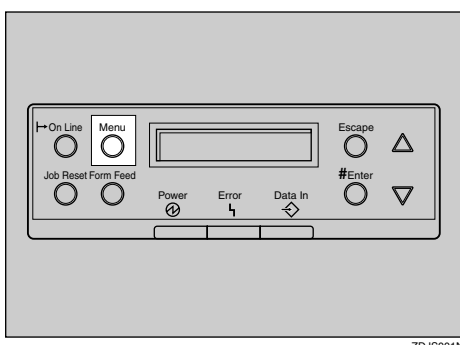

ZDJS001N

"Menu" appears on the display.

2 Press **[▲]** or **[▼]** to display "Paper Input", and then press **[Enter #]**.

```
Menu:
Paper Input
```

The paper selection menu appears.

3 Press **[▲]** or **[▼]** to display "Paper Type", and then press **[Enter #]**.

```
Paper Input:
Paper Type
```

The paper tray selection menu appears.

4 Press **[▲]** or **[▼]** to display the target paper tray, and then press **[Enter #]**.

```
Paper Type:
Tray 2
```

The paper type selection menu appears.

5 Press **[▲]** or **[▼]** to display the loaded paper type, and then press **[Enter #]**.

```
Tray 2
Recycled Paper
```

After about two seconds, the display returns to the menu.

6 Press **[On Line]**.

"Ready" appears on the display.

```
Ready
```

Loading Paper in the Bypass Tray

Besides regular paper, you can use the bypass tray to load thick paper, envelopes, OHP transparencies, paper longer than A3, and paper that cannot be loaded in the paper trays or paper feed unit.

Note

- ❑ The bypass tray can accommodate sheets 90-305 mm wide and 148-457 mm long. However, the paper size must be set using the control panel. When using the RPCS printer driver, sheets of up to 1260 mm in length can be set.
- ❑ If you load custom size paper or special paper, select the paper size using the control panel. The RPCS printer driver can select the paper size using the printer driver properties. The paper size selected using the printer driver overrides that selected using the control panel. See p.58 “Specifying custom size paper for the Bypass Tray”.
- ❑ If you load thick paper, OHP transparencies, or envelopes, make the settings for thick paper or OHP transparencies using the control panel or printer driver. See p.59 “Specifying a paper type for the Bypass Tray”.
- ❑ The number of pages that can be loaded in the bypass tray differs depending on paper type. Check that the top of the stack is not higher than the limit mark inside the tray.
- ❑ When loading paper in the bypass tray, use landscape orientation if possible.

Limitation

- ❑ You cannot use the following functions when printing on paper loaded in the bypass tray:
 - Duplex Print
 - Collate, Job Separation
 - Staple/Punch
 - Auto Tray Select

1 Open the bypass tray.

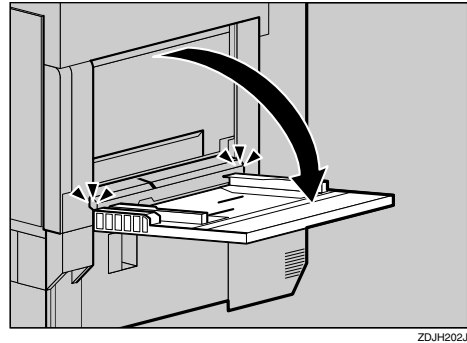

Note

- ❑ If you load A4 or larger size paper, pull out the bypass tray extension, and then flip it open.

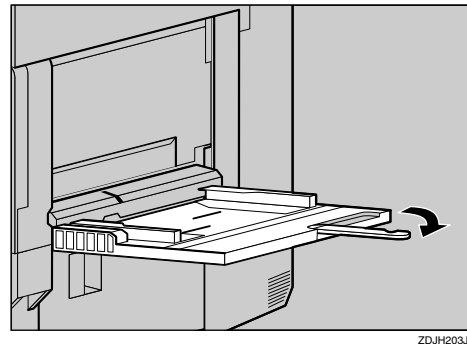

- 2** Slide the side guides outward (①), and then load paper print side up, until it stops (②).

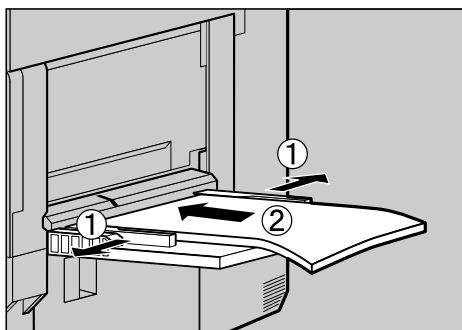

ZDJH204J

- 3** Adjust the side guides to fit the paper width.

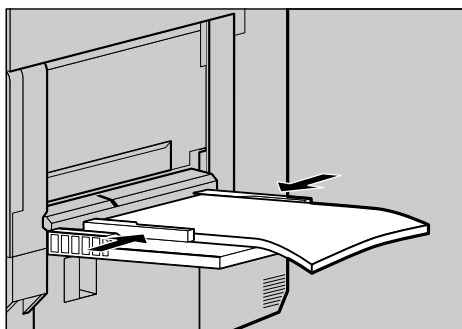

ZDJH205J

Important

- Check that the top of the stack is not higher than the limit mark inside the tray.
- Shuffle the paper before loading the stack onto the tray, so multiple sheets are not fed in together.

- 4** Set the paper size using the control panel as follows:

- 1** Press **[Menu]**.

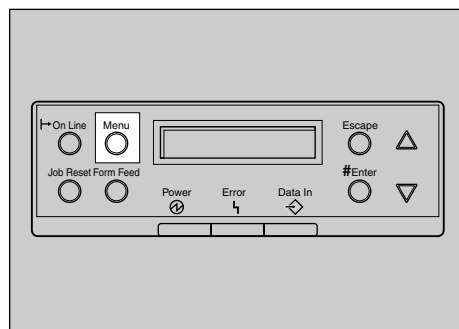

ZDJS001N

"Menu" appears on the display

- 2** Press **[▲]** or **[▼]** to display "Paper Input" menu, and then press **[Enter #]**.

The following message appears on the display:

```
Menu:
Paper Input
```

- 3** Check "Bypass Size" appears, and then press **[Enter #]**.

The following message appears on the display.

```
Paper Input:
BYPASS SIZE
```

- 4** Press **[▲]** or **[▼]** to display the size and orientation of the paper in the bypass tray.

```
Bypass Size
*11 X 17
```

After about two seconds, the display returns to the menu.

5 Press **[On Line]**.

“Ready ” appears on the display.



Specifying custom size paper for the Bypass Tray

Important

- The paper size selected using the printer driver overrides that selected using the control panel. You do not have to make settings using the control panel if you already made them using the printer driver. However, when printing with a printer driver other than the RPC-S™ printer driver, you must make the settings using the control panel. For details about the printer driver, see Help.
- The printer cannot print from applications that do not support custom size paper.

1 Press **[Menu]**.

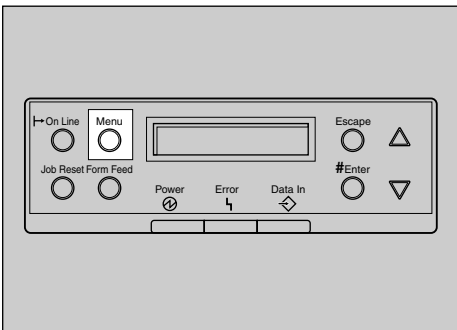

ZDJS001N

“Menu” appears on the display.

2 Press **[▲]** or **[▼]** to display “Paper Input”, and then press **[Enter #]**.

The following message appears on the display.



3 Check “Bypass Size” appears, and then press **[Enter #]**.

The following message appears on the display:

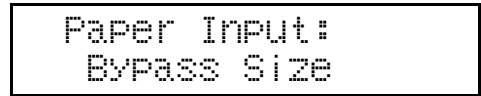

4 Press **[▲]** or **[▼]** to display “Custom Size”, and then press **[Enter #]**.

The following message appears on the display:

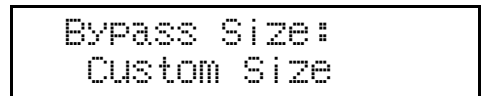

5 Press **[▲]** or **[▼]** to set the horizontal value, and then press **[Enter #]**.

The following message appears on the display:

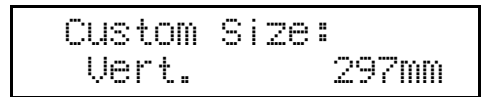

6 Press **[▲]** or **[▼]** to set the vertical value, and then press **[Enter #]**.

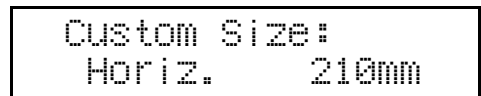

After about two seconds, the display returns to the menu.

7 Press **[On Line]**.

The following message appears on the display:

**Specifying a paper type for the Bypass Tray**

By selecting the paper type you want to load, the printer performs better. You can select from the following paper types:

- Plain Paper, Recycled Paper, Special Paper, Color Paper, Letterhead, Preprinted Paper, OHP Transparencies, Thick Paper, Plain Paper (Duplex), Thick Paper (Duplex)

! Limitation

- You cannot use the following functions when printing on paper loaded in the bypass tray:
 - Duplex Print
 - Collate, Job Separation
 - Staple, Punch
 - Auto Tray Select

! Important

- Be sure to select the paper type when you load labels, thick paper, or OHP transparencies in the Bypass Tray.

Note

- When printing labels, select thick paper as the paper type.

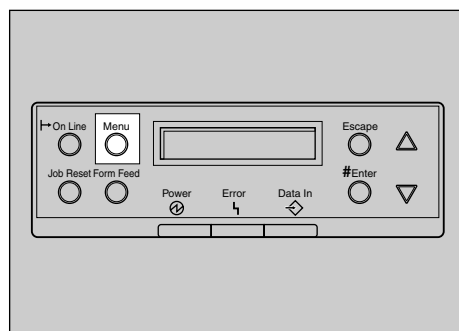
1 Press **[Menu]**.

“Menu” appears on the display.

2 Press **[▲]** or **[▼]** to display “Paper Input”, and then press **[Enter #]**.

The following message appears on the display:

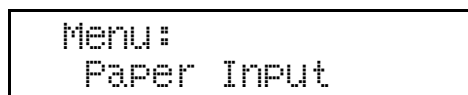
**3** Press **[▲]** or **[▼]** to display “Paper Type”, and then press **[Enter #]**.

The following message appears on the display:

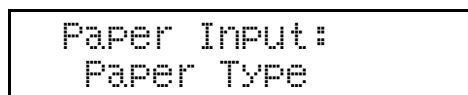
**4** Press **[▲]** or **[▼]** to display “Bypass Tray”, and then press **[Enter #]**.

The following message appears on the display:

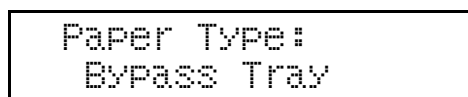

- 5** Press **[▲]** or **[▼]** to display the target paper type, and then press **[Enter #]**.

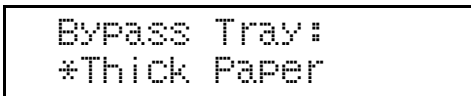

BYPASS TRAY:
*THICK PAPER

After about two seconds, the display returns to the menu.

- 6** Press **[On Line]**.

The following message appears on the display:



Ready

4. Troubleshooting

Error & Status Messages on the Control Panel

❖ Status Messages

Messages/Second messages	Causes	Solutions
Calibrating...	The printer is calibrating color.	Wait a while
Energy Save Mode	In Energy Save Mode Level 2.	No action required.
Hex Dump Mode	In Hex Dump Mode.	No action required.
Loading Toner...	The printer is loading toner.	Wait a while
Offline	The printer is offline and cannot print data.	Press [On Line] .
Initializing... Please Wait	The printer is initializing the development unit.	Wait a while
Printing...	The printer is performing a print job.	Wait a while
Processing...	Print data is being processed.	Wait a while
Ready	The default ready message. The printer is ready to use.	No action required.
Resetting Job...	Job is being reset.	Wait a while
Waiting...	The printer is waiting for the next data to print.	Wait a while
Warming Up...	The printer is warming up and not ready.	Wait until the printer signals Ready.

❖ Alert Messages

Messages/Second messages	Causes	Solutions
Add Staples	The stapler is out of staples. Job is not stapled.	Replace staples. See p.93 "Adding Staples".
Add Toner/Yellow/Magenta/Cyan/Black	The printer is out of the indicated toner(s).	Replace the toner cartridge of the indicated color(s). See p.2 "Replacing the Toner Cartridge".
Add Toner Black	The printer is out of toner (K).	Replace the toner cartridge (K). See p.2 "Replacing the Toner Cartridge".

Messages/Second messages	Causes	Solutions
Add Toner Cyan	The printer is out of toner (C).	Replace the toner cartridge (C). See p.2 "Replacing the Toner Cartridge".
Add Toner Magenta	The printer is out of toner (M).	Replace the toner cartridge (M). See p.2 "Replacing the Toner Cartridge".
Add Toner Yellow	The printer is out of toner (Y).	Replace the toner cartridge (Y). See p.2 "Replacing the Toner Cartridge".
Call Service: EC Power Off On /If Error Reoccur Call Service	A communication error sent from the engine to the controller.	Turn the power off and then on. If the message appears again, contact your sales or service representative.
Change Setting Tray # /Paper Size: Paper Type:	The paper size and type setting in the tray differs from that of actual paper size and type in the tray.	Load {paper size and type} paper in the selected feed direction into the tray, and then change the paper size and type using the control panel. Or, press 【Form Feed】 , and then select the tray using the control panel. Or, press 【Job Reset】 to cancel the print job.
Cannot check Signal in Ad hoc	An attempt to check the radio signal was made while the communication mode was set to 【Ad hoc】 in the interface settings.	To check the radio signal, select Infrastructure in the communication mode settings.
Close Duplex Unit Cover	The cover for the duplex unit is open.	Close the cover for the duplex unit.
Close Finisher Front Cover	The front cover for the finisher is open.	Close the front cover for the finisher.
Close Right Cover	The upper right cover (the cover for the toner cartridge) is open.	Close the upper right cover.
Close Finisher Upper Cover	The finisher upper cover is open.	Close the upper cover for the finisher.
Close Finisher Upper Cover	The paper entrance cover for the finisher is open.	Close the upper entrance cover for the finisher.
Close Front Cover	The front cover is open.	Close the front cover for the printer.

Messages/Second messages	Causes	Solutions
Close Lower Right Cover	The right cover for the paper feed table/Large Capacity Tray is open.	Close the right cover for the paper feed table/Large Capacity Tray.
Close Mailbox Cover	The cover for the 4-bin mailbox is open.	Close the cover for the 4-bin mailbox tray.
Close Right Cover	The right cover is open.	Close the right cover.
Close Upper Left Cover	The upper left cover (the cover for the fusing unit) is open.	Close the upper left cover.
DHCP assigned Cannot change	An attempt to change the IP address, subnet mask or gateway address was made while DHCP was set to [On] .	Make the change after setting DHCP to [Off] .
Driver Setting Error (Memory)	The printer identified a download error. This error may occur when the installed memory amount is less than the driver setting.	Verify paper memory size is specified with the driver setting.
Duplex Cancelled	The setting of Duplex Print has been cancelled.	(a) To print the image correctly, add memory to the printer. (b) Be sure to use the correct paper.
Error: Enter 10 or 26 characters	An ID with an invalid number of digits was entered for the WEP key.	Enter the correct number of digits for the WEP key.
Error:Tray 1 Reset The Job /Then Power OffOn	There is a problem with the current specified tray. The job cannot be processed.	Reset the job, and then turn the printer Off, then back On.
Error:Tray 1 Form Feed /Or Job Reset Then Power OffOn	The printer identified the failure of the indicated paper tray. The job is not printed.	Apply Form Feed from another tray or cancel the job, and then switch your printer Off, then back On. If the error continues, contact your sales or service representative.
Exceeded Max. Pages (Collate)	The printer identified a collation page overflow error.	Add extra RAM. Install the optional hard disk drive.
Exceeded Max. Stored Files	The maximum number of stored files has been exceeded during Sample Print of Locked Print.	Delete stored files.
Exceeded Max. Stored Pages	The maximum number of pages has been exceeded during Sample Print of Locked Print	Reduce the number of pages to print.

Messages/Second messages	Causes	Solutions
Hardware Problem DIMM	The printer identified a DIMM sum value error.	Remove and re-install the DIMM correctly. Remove any dust under the DIMM. If the message appears again, contact your sales or service representative. See "Setting Up", <i>Setup Guide</i> .
Hardware Problem Ethernet	The printer identified an Ethernet error.	Turn the power off, and then on. If the message appears again, contact your sales or service representative.
Hardware Problem Finisher	There is a problem with the finisher.	Turn the power off, and then on. Remove and re-install the finisher correctly. If the message appears again, contact your sales or service representative. See "SR770 (2 Tray Finisher)", <i>Setup Guide</i> .
Hardware Problem HDD	The printer identified a HDD board error.	Turn the power off, and then on. Remove and re-install the HDD board correctly. If the message appears again, contact your sales or service representative. See "Printer Hard Disk Type 7000", <i>Setup Guide</i> .

Messages/Second messages	Causes	Solutions
Hardware Problem IEEE1394	The printer identified an IEEE1394 board error.	<p>Turn the power off, and then on.</p> <p>Remove and re-install the IEEE 1394 board correctly.</p> <ol style="list-style-type: none"> ① Check the 1394 Interface Unit Type 4510 is correctly attached to the computer. ② Check the IEEE 1394 interface cable is securely connected. ③ Unplug the IEEE 1394 interface cable which is connected to the printer. ④ Restart the computer. If the message appears even after executing above operation, proceed to the following steps. ⑤ Execute the utility tool for 1394 Interface Unit Type 4510 that is stored in the following path in the CD-ROM labeled "Printer Drivers and Utilities": UTILITY\1394 <p> Important</p> <ul style="list-style-type: none"> <input type="checkbox"/> For details about using the utility tool for IEEE1394, see the README file in the same directory in the CD-ROM. <p>If the message appears again, contact your sales or service representative.</p> <p>See "1394 Interface Unit Type 4510", <i>Setup Guide</i>.</p>
Hardware Problem NV-RAM	The printer identified a Memory Switch (user account enhance unit) error.	<p>Turn the power off, and then on. Remove and re-install the user account enhance unit correctly.</p> <p>If the message appears again, contact your sales or service representative.</p> <p>See "User Account Enhance Unit TypeC", <i>Setup Guide</i>.</p>

Messages/Second messages	Causes	Solutions
Hardware Problem Option RAM	The printer identified an optional RAM error.	<p>Turn the power off, and then on.</p> <p>Remove and re-install the optional RAM.</p> <p>If the message appears again, contact your sales or service representative.</p> <p>See "Memory Unit TypeC (SDRAM Module)", <i>Setup Guide</i>.</p>
Hardware Problem Parallel I/F	There is a problem with the parallel interface.	If you use the parallel I/F, replace the interface cable that caused the error. Turn the power off, and then on. If the message appears again, contact your sales or service representative.
Hardware Problem Staple Unit	There is a misfeed in the finisher or a problem with the staple unit.	<p>Remove misfed paper. Turn the power off, and then on. If the message appears again, contact your sales or service representative.</p> <p>See p.85 "When "Remove Misfeed R: Finisher" Appears".</p> <p>See p.91 "Removing Jammed Staples".</p>
Hardware Problem Tray 1	There is a problem with the paper lift motor of Tray 1.	Turn the power off, and then on. If the message appears again, contact your sales or service representative.
Hardware Problem Tray 2	There is a problem with the paper lift motor of Tray 2.	Turn the power off, and then on. If the message appears again, contact your sales or service representative.
Hardware Problem Tray 3	There is a problem with the paper lift motor of Tray 3.	<p>Align paper and set it in the correct position in Tray 3.</p> <p>Turn the power off, and then on. If the message appears again, contact your sales or service representative.</p>
Hardware Problem Tray 4	There is a problem with the paper lift motor of Tray 4.	Turn the power off, and then on. If the message appears again, contact your sales or service representative.

Messages/Second messages	Causes	Solutions
Hardware Problem Wireless Board	An error was detected in the 802.11b interface unit or the Bluetooth interface unit.	Turn the power off, and then on. Remove and re-install the 802.11b interface unit or the Bluetooth interface unit correctly. If the message appears again, contact your sales or service representative. See "802.11b Interface Unit Type A", or "Bluetooth Unit Type 2045", <i>Setup Guide</i> .
Hardware Problem Wireless Card	The 802.11b interface unit or the Bluetooth interface unit could not be detected when the power was turned on. The 802.11b interface card or the Bluetooth interface card was removed after the power was turned on. An error was detected in the 802.11b interface card or the Bluetooth interface card.	Turn the power off, and then on. Remove and re-install the 802.11b interface unit or the Bluetooth interface unit correctly. If the message appears again, contact your sales or service representative. See "802.11b Interface Unit Type A", or "Bluetooth Unit Type 2045", <i>Setup Guide</i> .
Hardware Problem USB	An error was detected in the USB 2.0 interface board.	Turn the power off, and then on. Remove and re-install the USB 2.0 interface board correctly. If the message appears again, contact your sales or service representative. See "USB 2.0 Interface Board Type A", <i>Setup Guide</i> .
HDD Full	The maximum HDD area size for form/font has been exceeded.	Delete disused form /font types.
	An HDD overflow error occurred during Sample Print or Locked Print.	Delete stored files, or reduce the size of the Sample Print file or Locked Print file.
HDD Not Installed	The user tried to print the Locked Print data without the HDD installed.	If you use the Locked Print feature, be sure you install HDD. If the error continues, contact your sales or service representative.
I/O Buffer Overflow	The maximum size of the I/O buffer has been exceeded.	Increase the size of the I/O buffer through the I/F Setup.
Invalid Password Try Again	The password entered using the control panel is not correct.	Enter the correct password using the control panel.

Messages/Second messages	Causes	Solutions
Load Correct Size Paper /Press # To Continue	The paper size setting in the tray differs from that of the actual paper size in the tray.	Load {paper size} paper in the selected feed direction into the tray, and then change the paper size with the control panel. Or, press 【Form Feed】 , and select the tray with the control panel. Or, press 【Job Reset】 to cancel the print job.
Load Paper Tray #	The indicated tray is out of paper. #: tray number	Load paper into the indicated paper tray.
Load Paper /Paper Size: Paper Type:	1:The printer received a request for a paper type, or paper size not supported by printer, and Tray Locking is not applicable. 2:The paper type and size loaded in the tray which the printer searched using Tray Locking is invalid for Duplex Print.	Change the setting of the indicated paper input tray, or press 【Job Reset】 . Form Feed is not possible here.
Menu Protected Cannot Change	The menu is protected and the setting cannot be changed.	Wait for two seconds until the previous display appears.
No Files Exist	There are no files available for Sample Print job or Locked Print job.	Wait for two seconds until the previous display appears.
Paper Invalid for Duplex:Tray# /Change Setting or Form Feed	The printer detected the setting of the indicated tray is invalid for Duplex Tray. #: tray number	Change the setting of the indicated paper input tray, or apply Form Feed using another tray, or press 【Job Reset】 .
Punch-hole Chips are Full	The Punch Chips container is full of punch chips.	Empty the punch waste box. See p.95 "Removing Punch-hole Chips". If the message appears the punch waste box is not full, remove the Punch-hole chips on the top of the punch waste box. See p.95 "If the message appears even after removing the Punch-hole chips".

Messages/Second messages	Causes	Solutions
Remove MisfeedA:Internal Path /See Instructions in Front Cover	There is a misfeed in the printer.	Remove the misfed paper following the instructions inside the front cover. For details, see p.82 "When "Remove Misfeed A:Internal Path" Appears".
Remove MisfeedB: Fusing Unit /See Instructions in Front Cover	There is a misfeed in the fusing unit.	Remove the misfed paper following the instructions inside the front cover. For details, see p.83 "When "Remove Misfeed B: Fusing Unit" Appears".
Remove MisfeedR: Finisher /Open Front Cover	There is a misfeed in the finisher.	Open the finisher cover and remove the misfed paper. For details, see p.85 "When "Remove Misfeed R: Finisher" Appears".
Remove MisfeedW: Mailbox /Open Mailbox Cover	There is a misfeed in the output 4-bin tray.	Open the mailbox cover and remove the misfed paper. For details, see p.84 "When "Remove Misfeed W: Mailbox" Appears".
Remove MisfeedY: Paper Tray /See Instructions in Front Cover	There is a misfeed in the specified input tray, or the printer is not feeding paper.	Remove the misfed paper following the instructions inside the front cover. For details, see p.87 "When "Remove Misfeed Y: Paper Tray" Appears".
Remove Misfeed: Duplex Unit /See Instructions in Front Cover	There is a misfeed in the duplex unit.	Remove the misfed paper following the instructions inside the front cover. For details, see p.87 "When "Remove Misfeed :Duplex Unit" Appears".
Remove Misfeed: Dup.Feed Unit /See Instructions in Front Cover	There is a misfeed in the duplex feed unit.	Remove the misfed paper. See p.88 "Removing Misfed Paper in the Duplex Feed Unit".
Remove Paper All Output Trays	All output trays are full.	Remove paper from all output trays.
Remove Paper Finisher Tray #	The indicated finisher shift tray is full. #:finisher shift tray number	Remove the paper from the indicated finisher shift tray.
Remove Paper From Upper Tray	The upper tray (output 1-bin tray) is full.	Remove paper from the upper tray.

Messages/Second messages	Causes	Solutions
Remove Paper Inside Finisher	There is still paper in the finisher.	Open the cover for the finisher and remove paper. See p.85 "When "Remove Misfeed R: Finisher" Appears".
Remove Paper Inside Finisher	A communication error is sent from the system unit to the duplex unit.	Remove and re-install the duplex unit. If the problem continues, contact your sales or service representative.
Remove Paper Mailbox Tray #	The output tray # of the optional 4-bin mailbox is full. # = mailbox tray number	Remove paper from the indicated 4-bin mailbox tray.
Remove Paper Standard Tray	The standard output tray is full.	Remove paper from standard output trays.
Replace Black Dev. Unit (Type D)	It is time to replace the black development unit	Replace the black development unit. Depending on your service contract, contact your sales or service representative. See p.15 "Replacing the Development Unit".
Replace Black PCU (Type F)	It is time to replace the black PCU.	Replace the black PCU. Depending on your service contract, contact your sales or service representative. See p.11 "Replacing the Photoconductor Unit".
Replace Color Dev. Unit (Type B)	It is time to replace the color development unit.	Replace the color development unit. Depending on your service contract, contact your sales or service representative. See p.15 "Replacing the Development Unit".
Replace Color PCU (Type A)	It is time to replace the color PCU.	Replace the color PCU. Depending on your service contract, contact your sales or service representative. See p.11 "Replacing the Photoconductor Unit".
Replace Feed Roller (Type H)	It is time to replace the feed roller (Type H).	Replace the feed roller. Depending on your service contract, contact your sales or service representative. See p.26 "Replacing the Paper Feed Rollers".

Messages/Second messages	Causes	Solutions
Replace Fuser Oil Unit (Type G)	It is time to replace the fuser oil unit.	Replace the fuser oil unit. Depending on your service contract, contact your sales or service representative. See p.7 "Replacing the Fuser Oil Unit".
Replace Fuser Oil Unit soon (Type G)	The fuser oil unit should be replaced soon.	Prepare to replace the fuser oil unit. Depending on your service contract, contact your sales or service representative. See p.7 "Replacing the Fuser Oil Unit".
Replace Fusing Unit (Type C)	It is time to replace the fusing unit.	Replace the fusing unit. Depending on your service contract, contact your sales or service representative. See p.19 "Replacing the Fusing Unit".
Replace Waste Toner (Type E)	It is time to replace the waste toner.	Replace the waste toner bottle. Depending on your service contract, contact your sales or service representative. See p.24 "Replacing the Waste Toner Bottle".
Reset Cyan Toner Correctly	The cyan cartridge is not installed, is installed incorrectly, or not the right type.	Install a cyan cartridge suitable for the machine. See "Installing the Toner Cartridge", <i>Setup Guide</i> .
Reset Develop. Unit Correctly /Yellow/Magenta Cyan/Black	The indicated development unit(s) is/are not set correctly, or not set.	Set the indicated development unit(s) correctly. See p.15 "Replacing the Development Unit".
Reset Duplex Unit Correctly	The duplex paper feed unit is not set correctly or not set.	Remove and re-install the duplex paper feed unit. If the error continues, contact your sales or service representative. See "Duplex Unit Type 7000", <i>Setup Guide</i> .
Reset Finisher Correctly	The finisher is not set correctly, or not set.	Set the finisher correctly. See "SR770 (2 Tray Finisher)", <i>Setup Guide</i> .
Reset Fuser Oil Unit Correctly	The fuser oil unit is not set correctly, or not set.	Set the fuser oil unit correctly. See p.7 "Replacing the Fuser Oil Unit".

Messages/Second messages	Causes	Solutions
Reset Fusing Unit Correctly	There is no fusing unit, or the fusing unit is not installed correctly.	Set the fusing unit correctly. See p.19 "Replacing the Fusing Unit".
Reset Magenta Toner Correctly	The magenta cartridge is not installed, is installed incorrectly, or not the right type.	Install a magenta cartridge suitable for the machine. See "Installing the Toner Cartridge", <i>Setup Guide</i> .
Reset Waste Oil Bottle correctly	The waste oil bottle is not set correctly, or not set.	Contact your sales or service representative.
Reset PCU Correctly /Yellow/Magenta Cyan/Black	The indicated photoconductor unit(s) is/are not set correctly, or not set.	Set the indicated photoconductor unit(s) correctly. See p.11 "Replacing the Photoconductor Unit".
Reset Toner Black	The indicated toner cartridge is not set correctly.	Set the indicated toner cartridge(s) correctly. See "Installing the Toner Cartridge", <i>Setup Guide</i> .
Reset Toner Cyan	The indicated toner cartridge is not set correctly.	Set the indicated toner cartridge(s) correctly. See "Installing the Toner Cartridge", <i>Setup Guide</i> .
Reset Toner Magenta	The indicated toner cartridge is not set correctly.	Set the indicated toner cartridge(s) correctly. See "Installing the Toner Cartridge", <i>Setup Guide</i> .
Reset Toner Yellow	The indicated toner cartridge is not set correctly.	Set the indicated toner cartridge(s) correctly. See "Installing the Toner Cartridge", <i>Setup Guide</i> .
Reset Transfer Unit Correctly	The transfer unit is not set correctly, or not set.	Contact your sales or service representative.
Reset Tray 1 Correctly	The indicated paper input tray is not set correctly, or not set.	Set the indicated paper input tray correctly.
Reset Tray Correctly	The printer detected, when processing a job through Auto Tray Select, that a paper input tray is not set correctly, or not set.	Set the indicated paper input tray correctly.
Reset Waste Toner Correctly	The waste toner bottle is not set correctly, or not set.	Set the waste toner bottle correctly.

Messages/Second messages	Causes	Solutions
Reset Yellow Toner Correctly	The yellow cartridge is not installed, is installed incorrectly, or not the right type.	Install a yellow cartridge suitable for the machine. See "Installing the Toner Cartridge", <i>Setup Guide</i> .
RPCS Graphic Error	The graphic is not initialized because graphic memory was not reserved.	Replace installed memory.
RPCS Memory Overflow	Printer memory is not initialized because CDC memory was not reserved via system call.	Replace installed memory.
RPCS Syntax Error	The printer identified a syntax error. This error results from data corruption caused by transmission problems, interruption, data transmission from other drivers, etc.	Be sure to use the correct driver.
SC XXX-X Power Off On /If Error Reoccur Call Service	The Service Code or SC number indicates the nature of the problem.	Turn the power off, and then on. If the message appears again, contact your sales or service representative.
SSID not entered	This message appears if the SSID has not been entered.	Enter the SSID.
Staple Cancelled	The Staple feature has been cancelled.	Check the paper orientation and layout is properly set, and make sure required settings for the finisher are selected.
Toner is Almost Empty: Black	The printer is almost out of toner (K).	Prepare to replace the toner cartridge (K).
Toner is Almost Empty: Cyan	The printer is almost out of toner (C).	Prepare to replace the toner cartridge (C).
Toner is Almost Empty: Magenta	The printer is almost out of toner (M).	Prepare to replace the toner cartridge (M).
Toner is Almost Empty: Yellow	The printer is almost out of toner (Y).	Prepare to replace the toner cartridge (Y).
Waste Toner is Almost Full (E)	The waste toner bottle is almost full.	Prepare to replace the waste toner bottle. Depending on your service contract, contact your sales or service representative. See p.100 "Consumables".
Waste Oil Bottle is Full	The waste oil bottle is full.	Contact your sales or service representative.
Waste Oil is Almost Full	The waste oil bottle is almost full.	Contact your sales or service representative.

Printer Does Not Print

4

Possible cause	Solutions
Is the power on?	Check the cable is securely plugged into the power outlet and the printer. Turn on the power.
Does the Online indicator stay on?	Press [On Line] so the indicator lights.
Does the Error indicator stay red?	Check the error message on the display and take the required action.
Is paper loaded?	Load paper into the paper tray or onto the bypass tray. See p.39 "Paper and Other Supported Media".
Can you print a configuration page?	If you cannot print a configuration page, a printer malfunction is likely. You should contact your sales or service representative. See "Printing a Configuration Page", <i>Administrator Reference</i> .
Is the interface cable connecting the printer to the computer connected securely?	Connect the interface cable properly. If there are any connectors or screws, check they are fastened securely.
Are you using the correct interface cable?	The type of interface cable you should use depends on the computer. Be sure to use the correct one. If the cable is damaged or worn, replace it. See "Appendix", <i>Administrator Reference</i> .

Possible cause	Solutions
Is the Data In indicator blinking or lit after starting the print job?	<p>If it is not blinking or lit, data is not being received.</p> <p>❖ If the printer is connected to the computer using the interface cable</p> <p>Make sure the following printer port settings are correct:</p> <ul style="list-style-type: none"> • For parallel port connection, port LPT1 or LPT2 should be set. • For IEEE 1394 (SCSI print) port connection, port 1394_00(n)^{*1} should be set. <p>^{*1} (n) is the number of printers connected.</p> <ul style="list-style-type: none"> • Windows 95/98/Me <ol style="list-style-type: none"> ① Click [Start], point to [Settings], and then click [Printers]. ② Click to select the printer icon. Next, on the [File] menu, click [Properties]. ③ Click the [Details] tab. ④ Check the [Print to the following port] box to confirm that the correct port is selected. • Windows 2000 <ol style="list-style-type: none"> ① Click [Start], point to [Settings], and then click [Printers]. ② Click to select the icon of the printer. Next, on the [File] menu, click [Properties]. ③ Click the [Port] tab. ④ Check the [Print to the following port] box to confirm the correct port is selected. • Windows XP <ol style="list-style-type: none"> ① Access the [Printers and Faxes] window from [Start] on the taskbar. ② Click to select the icon of the printer. Next, on the [File] menu, click [Properties]. ③ Click the [Port] tab. ④ Check the [Print to the following port(s).] box to confirm that the correct port is selected. • Windows NT 4.0 <ol style="list-style-type: none"> ① Click [Start], point to [Settings], and then click [Printers]. ② Click to select the icon of the printer. Next, on the [File] menu, click [Properties]. ③ Click the [Port] tab. ④ Check the [Print to the following port] box to confirm the correct port is selected. <p>❖ Network Connection</p> <p>Contact your network administrator.</p>

Possible cause	Solutions
<p>When you use 1394 Interface Unit Type 4510</p>	<ul style="list-style-type: none"> ① Check the 1394 Interface Unit Type 4510 is attached to the computer correctly. ② Check the IEEE 1394 interface cable is connected securely. ③ Restart the computer. If the error occurs even after executing the above, proceed to the following steps. ④ Unplug the IEEE 1394 interface cable connected to the printer. ⑤ Execute the utility tool for 1394 Interface Unit Type 4510 is stored in the following path on the CD-ROM labeled "Printer Drivers and Utilities". UTILITY\1394 <p>⚠ Important</p> <ul style="list-style-type: none"> <input type="checkbox"/> For details about using the utility tool for IEEE 1394, see the README file in the same directory on the CD-ROM.

4

Other Printing Problems

Problem	Possible causes and solutions
Black areas and lines are printed with an unnatural hue.	<ul style="list-style-type: none"> • PCL 5c/PostScript 3 Select [CMY+K] for Gray Reproduction in the printer driver's [Advanced] dialog box under the [Print Quality] tab. • RPCS Select [CMY+K] for Gray Reproduction under the [Image Adjustments] tab in the printer driver's [Change Use Setting] dialog box.
Color documents are printed in black and white.	<p>The printer driver is not set up for color printing.</p> <ul style="list-style-type: none"> • PCL 5c/PostScript 3 Select [Color] for the Color/Black and White under the printer driver's [Setup] tab. • RPCS Select [Color] for the Color/Black and White under the printer driver's [Print Settings] tab. <p>For details, see the printer driver Help.</p>
	Some applications normally print color text as black and white.
Fine dot pattern does not print.	<ul style="list-style-type: none"> • PCL 5c/PostScript 3 Change the [Dithering] setting in the [Advanced] dialog box under the printer driver's [Print Quality] tab. • RPCS Change the [Dithering] setting under the [Image Adjustments] tab in the [Change User Settings] dialog box under the [Print Quality] tab in the printer properties dialog box. <p>For details, see the printer driver Help.</p>
Images are cut off, or excess pages are printed.	<p>You might be printing on paper that is smaller than the size selected in the application. Use paper the same size as that selected in the application. If you cannot load paper of the correct size, use the reduction function to reduce the image, and then print.</p> <p>See the printer driver Help.</p>

Problem	Possible causes and solutions
<p>It takes too much time to complete the print job.</p>	<p>Photographs and other data-rich pages take a long time for the printer to process, so simply wait when printing such data.</p> <p>Changing the following settings may help speed up printing.</p> <ul style="list-style-type: none"> • PCL 5c Select [600 dpi] as the Resolution under the [Print Quality] tab in the printer properties dialog box. • PostScript 3 Select [1200 dpi] or [600 dpi] as the Resolution under the [Print Quality] tab in the printer properties dialog box. Select [Fast] as the Gradation under the [Print Quality] tab in the printer properties dialog box. Select [Post Script(optimize for speed)] as the PostScript 3 output format under the [PostScript] tab in the printer properties dialog box. • RPCS Select [1200x600 dpi] or [600x600 dpi] as the Resolution under the [Image Adjustments] tab in the [Change User Settings] dialog box in the printer dialog box. Select [Speed] Print priority under the [Print Quality] tab in the printer properties dialog box. <p>For details, see the printer driver Help.</p> <p>The data is so large or complex that it takes time to process. If the Data In indicator is blinking, data processing is in progress. Just wait until it resumes.</p> <p>If the “Warming Up...” message appears on the display, the printer is warming up. Wait a while</p> <p> Note</p> <p><input type="checkbox"/> To maintain optimum quality, color adjustment is regularly executed during or after printing. Even if printing is not specified, color adjustment is sometimes executed automatically while the power is on.</p>
<p>It takes too much time to resume printing.</p>	<p>The data is so large or complex that it takes time to process. If the Data In indicator is blinking, data processing is in progress. Just wait until it resumes.</p> <p>The printer might be in Energy Saver mode. In this mode, the printer has to warm up before printing can start, and this takes time. To change how long it takes before the printer goes into Energy Saver mode or to disable Energy Saver mode, configure Energy Saver 1 or Energy Saver 2 in the System menu.</p>
<p>Multiple pages are fed through the printer at once.</p>	<p>Paper misfeeds occur frequently when the paper feed roller is dirty. Contact your sales or service representative to replace the paper feed roller.</p>

Problem	Possible causes and solutions
Output are not delivered to the selected tray you require.	<p>When using the bypass tray, the size selected on the display might be different from actual paper size. Select the correct paper size.</p> <p>See p.39 "Paper and Other Supported Media".</p>
	<p>If you are using a Windows operating system, printer driver settings override those set using the control panel. Set the desired output tray using the printer driver.</p> <p>See the printer driver Help.</p>
Paper misfeeds occur frequently.	<p>Check the side guide of the paper tray is locked.</p> <p>See p.39 "Paper and Other Supported Media".</p> <p>Paper size and feed direction of paper in the Bypass Tray might not be the same as those selected using the control panel. Check the settings on the control panel, and load paper of the correct size and feed direction.</p> <p>See p.39 "Paper and Other Supported Media".</p>
	<p>Check the paper guide of the paper tray is attached properly.</p>
Solid areas, lines, or text are shiny or glossy when printed as a mixture of cyan, magenta, yellow.	<ul style="list-style-type: none"> • PCL 5c/PostScript 3 Select [K(Black)] for Gray Reproduction in the printer driver's [Advanced] dialog box under the [Print Quality] tab. • RPCS Select [K(Black)] for Gray Reproduction under the [Image Adjustments] tab in the printer driver's [Change Use Setting] dialog box.
Solid lines are printed as broken lines.	<ul style="list-style-type: none"> • PCL 5c/PostScript 3 Change the [Dithering] setting in the [Advanced] dialog box under the printer driver's [Print Quality] tab. • RPCS Change the [Dithering] setting under the [Image Adjustments] tab in the [Change User Settings] dialog box, under the [Print Quality] tab in the printer properties dialog box. <p>For details, see the printer driver Help.</p>
Some parts of the print image are not clear.	<p>Make the image density darker.</p> <p>To adjust image density, press [Menu] on the control panel, and then select Image Density from the Maintenance menu.</p>
The color of the printout is different from the color on the computer display.	<p>Toner based color settings under the printer driver produce unexpected printout colors.</p>
	<p>Changing color settings using the printer driver produces unexpected printout colors.</p> <p>See the printer driver Help.</p>
The image is printed in the wrong orientation.	<p>The feed direction you selected and the feed direction selected in Option Setup of the RPCS printer driver may be conflicting. Make the proper settings.</p>

Problem	Possible causes and solutions
Color registration shifts when printing in color on thick paper.	Press 【Menu】 , and then select Color Regist. from the Maintenance menu. See p.29 "Cleaning and Adjusting the Printer".
The control panel error message stays on after removing the misfed paper.	Open the front cover of the printer, and then close it.
The print image is not clear.	Due to sudden temperature change, condensation might appear inside the printer, reducing print quality. If you move the printer from a cold room to a warmer room, do not use until it acclimatizes to the temperature.
The print side of pages is hazy gray.	Adjust image density. To adjust image density, press 【Menu】 , and select Image Density from the Maintenance menu. See p.29 "Cleaning and Adjusting the Printer".
	If paper is curled, correct it. Curled or folded paper might result in hazy gray print. Curling often occurs with postcards, so be sure to correct it before printing.
Printed images are different to computer screen images.	When you use certain functions, such as enlargement and reduction, image layout might be different from that displayed on the computer screen.
	You might have selected to replace True Type fonts with printer fonts in the printing process. To print an image like that image on the computer screen, make settings to print out True Type fonts as an image. See the printer driver Help.
The printer does not print at 1200 dpi, even if 1200 dpi resolution is selected.	Printing at 1200 dpi is memory intensive. Therefore, depending on memory capacity, you may not be able to print at 1200 dpi. Either add memory to the printer, or reduce the size of data. See "Memory Capacity and Paper Size", <i>Administrator Reference</i> .
There are color differences in color documents.	Press 【Menu】 , and then select Color Regist. from the Maintenance menu. See p.29 "Cleaning and Adjusting the Printer".

 **Note**

- If the problem cannot be solved, contact your sales or service representative.

Removing Misfed Paper

If a paper misfeed occurs, an error message appears indicating the location of the misfed paper on the display.

❖ Misfeed Recovery

This printer has a misfeed recovery function that sends misfed paper to the standard tray or right cover. Usually, you can remove the misfed paper from one or other of these trays.

Detaching the 2 Tray Finisher

There are times when you may need to detach the 2 tray finisher from the printer to remove misfed paper. This section describes how to detach the 2 tray finisher.

- 1** Hold the handle at the top of the 2 tray finisher firmly using one hand, pull the 2 tray finisher straight out, and let go when it stops.

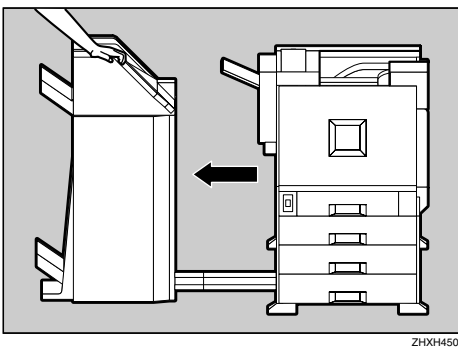

The 2 tray finisher is detached from the printer.

- 2** Use both hands to push it straight back in, and let go when it clicks into place.

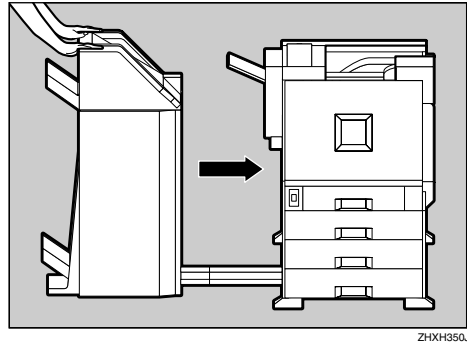

The 2 tray finisher is reattached to the printer.

⚠ Important

- Attach the 2 tray finisher to the printer after closing the duplex reversal unit.

Opening and Closing the Duplex Reversal Unit

There are times when you may need to detach the duplex reversal unit to remove misfed paper. This section describes how to detach the duplex reversal unit.

- 1** Push up the lock release button and leave it in place.

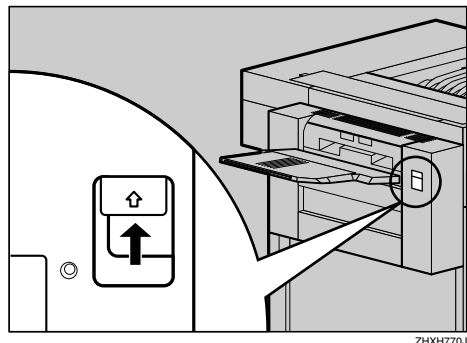

- 2 Slowly lower the duplex reversal unit, until it stops.

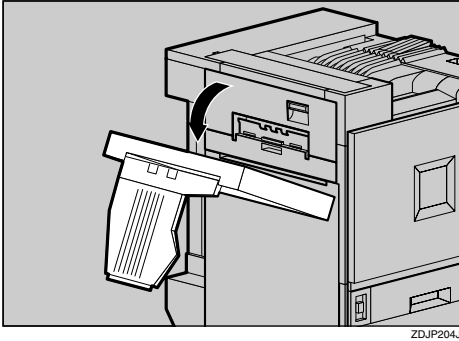

ZDJP204J

Important

- Open the duplex reversal unit after detaching the 2 tray finisher from the printer.

Note

- You do not have to remove the output tray, even if the 2 tray finisher is attached.

The duplex reversal unit is opened.

- 3 Slowly close the duplex reversal unit by raising it using both hands, and push it in until it clicks into place.

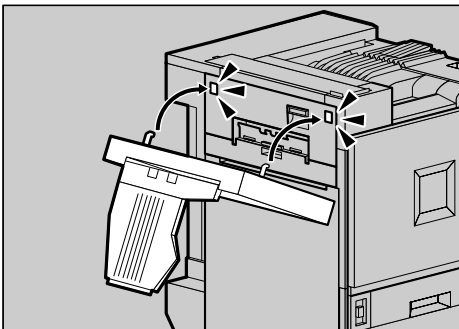

ZDJP205J

The duplex reversal unit is closed.

Important

- Attach the duplex reversal unit after closing the upper left cover for the printer.

When “Remove Misfeed A:Internal Path” Appears

- 1 Open the bottom-right cover by pulling its lever.

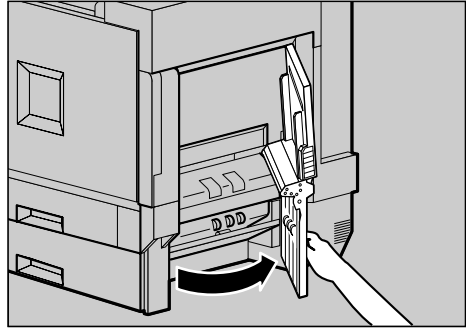

ZDJH206J

- 2 Move the blue lever up and down to feed the misfed paper, and then slowly pull out the paper.

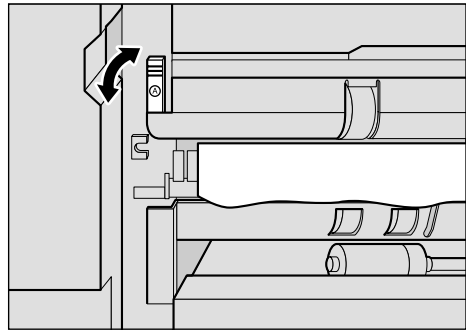

ZHXH205J

- 3 Close the right cover by pushing the area labeled “PUSH”.

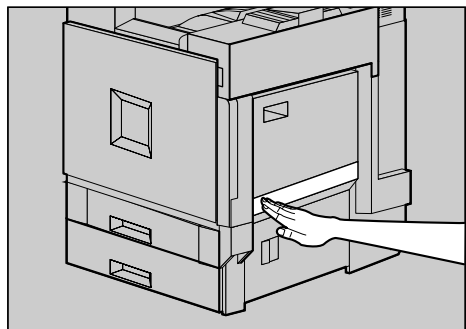

ZDJP708J

When “Remove Misfed B: Fusing Unit” Appears

⚠ CAUTION:

- The inside of the machine becomes very hot. Do not touch parts labelled “hot surface”. Touching a “hot surface” could result in a burn.

- 1 If the 2 tray finisher is installed, detach it from the printer.

🔍 Reference

p.81 “Detaching the 2 Tray Finisher”

- 2 If the duplex unit is installed, open the duplex reversal unit.

🔍 Reference

p.81 “Opening and Closing the Duplex Reversal Unit”

- 3 If the output tray is attached to the printer, raise it in the direction of the arrow (①), and then remove it (②).

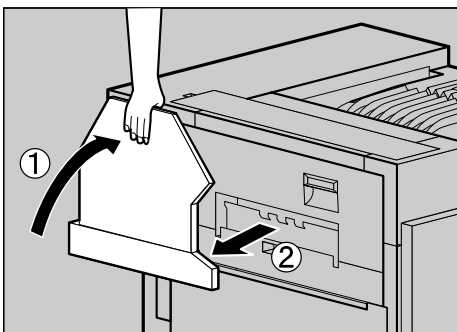

ZDJP038J

- 4 Slowly pull out the upper left cover for the printer.

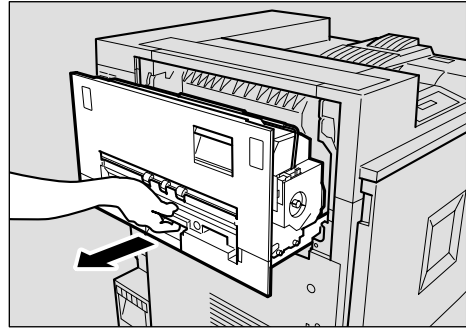

ZHXH010J

- 5 Open the upper left cover.

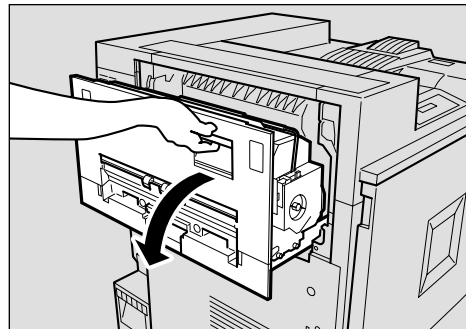

ZHXH020J

- 6 Turn the blue dial in the direction of the arrow to push out the misfed paper, and slowly pull out the paper.

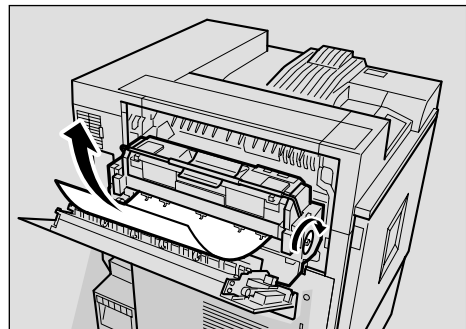

ZHXH670J

Important

- ❑ Always turn the blue dial in the direction of the arrow. If you turn it in the reverse direction, paper feeds into the printer, making it difficult for you to take out.
- ❑ Do not pull out misfed paper. Use the blue dial to push it.

7 Close the upper left cover (①) and push the part labeled "PUSH" next to the handle at the bottom rear, the back until it clicks (②).

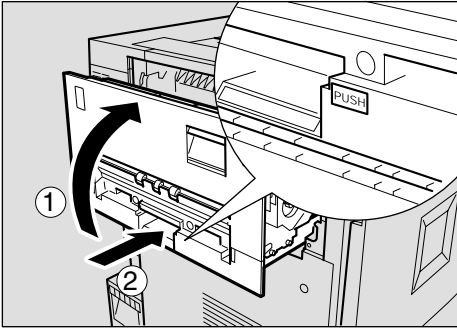

ZHXH082J

8 If you removed the output tray in step 3, reattach it to. Insert the hooks of the output tray into the printer slits, and then lower it toward you.

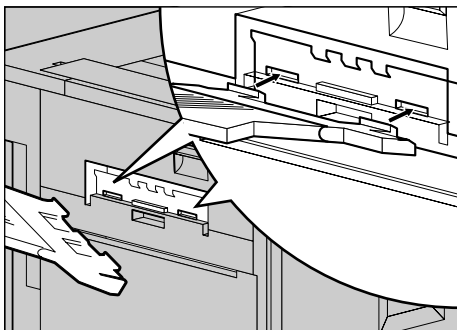

ZDJH010J

9 If the duplex unit is installed, close the duplex reversal unit.

Reference

p.81 "Opening and Closing the Duplex Reversal Unit"

10 If the 2 tray finisher is installed, reattach it to the printer.

Reference

p.81 "Detaching the 2 Tray Finisher"

When "Remove Misfeed W: Mailbox" Appears

1 Slowly open the mailbox cover (①), and then pull out the misfed paper (②).

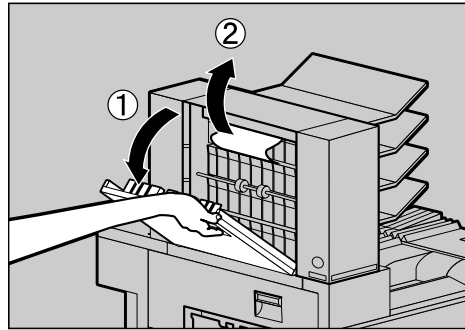

ZDJY207J

2 Close the mailbox cover.

When “Remove Misfed R: Finisher” Appears

Open the top cover (①) and front cover (②) of the 2 tray finisher, and then remove the misfed paper.

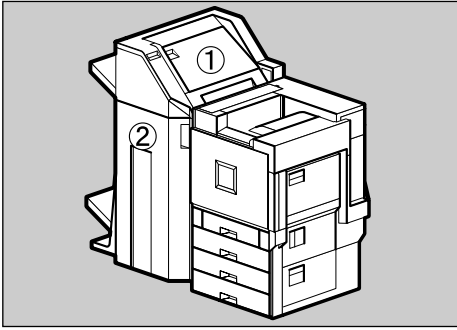

ZDJP206J

1 Fold the output tray.

① Raise it vertically.

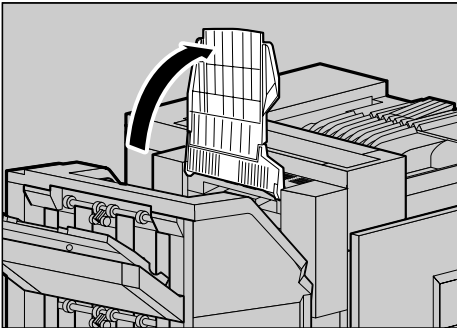

ZHXH680J

② Fold it over the printer top.

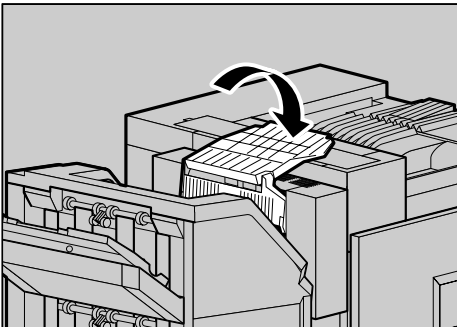

ZHXH690J

2 Open the top cover for the 2 tray finisher, and then slowly pull out the misfed paper.

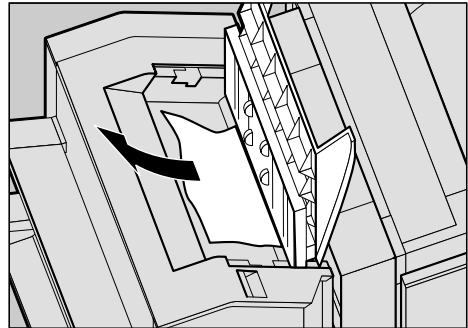

ZDJY208J

3 Close the top cover slowly.

4 Open the front cover for the 2 tray finisher.

Check to see if there is misfed paper in areas A, B, C, and D.

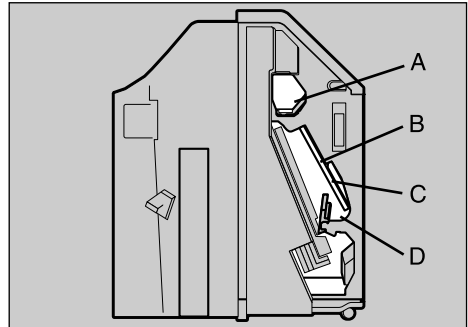

ZDJP209J

5 Check area A of step 4. Lift the lever (①), and then while holding it up with your hand, slowly pull out the misfed paper.

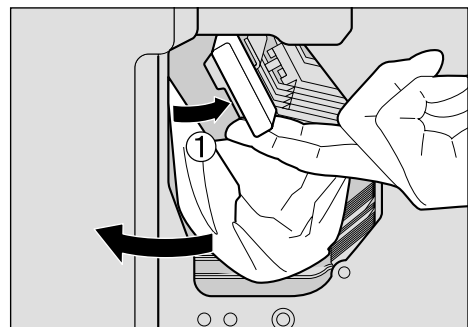

ZDJP210J

6 Slowly lower the lever to put it back into place.

7 Check areas B and C of step **4**. Lower the lever in the direction of the arrows (①), and then slowly pull out the misfed paper.

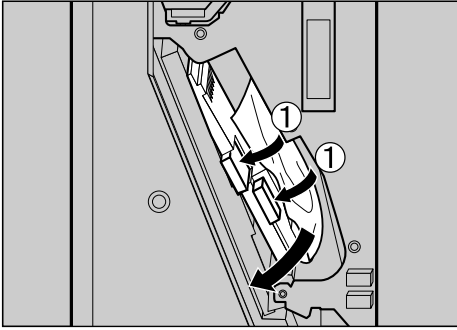

ZDJP211J

8 Slowly lift the lever to put it back into place.

9 Check area D of step **4**. Lift the lever in the direction of the arrow (①), and then slowly pull out the misfed paper.

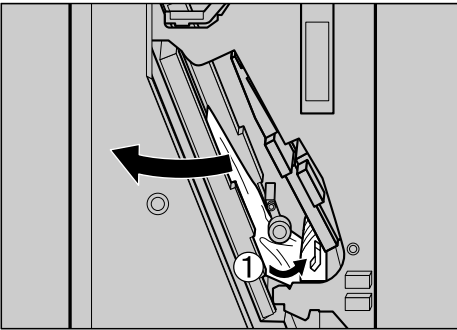

ZDJP212J

10 Slowly lower the lever to put it back into place.

11 Close the front cover of the 2 tray finisher.

If the error message does not disappear even after misfed paper is removed, detach the 2 tray finisher from the printer to check for misfed paper there.

Reference

p.81 "Detaching the 2 Tray Finisher" for details about how to detach/reattach the 2 tray finisher from/to the printer

12 Put the output tray back into place.

1 Raise the tray.

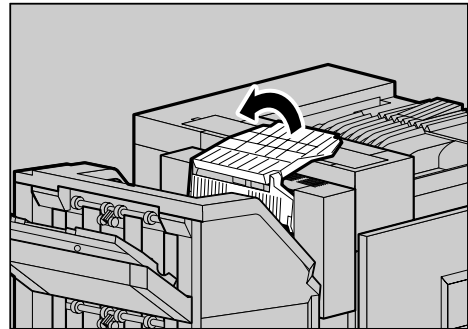

ZHXH360J

2 Lower it slowly.

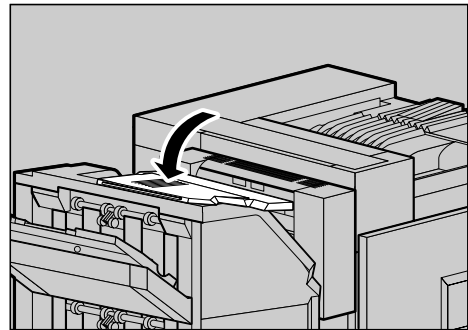

ZHXH370J

4

When “Remove Misfeed Y: Paper Tray” Appears

- 1 Open the lower right cover of the paper feed unit, and then pull out the misfed paper.

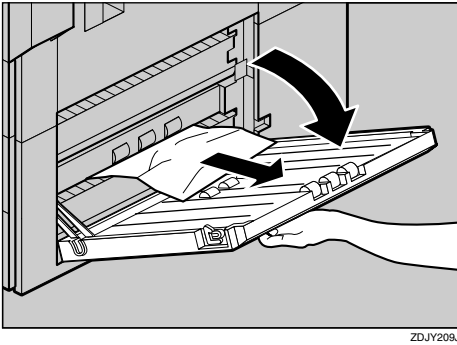

ZDJY209J

- 2 Close the lower right cover of the paper feed unit.

When “Remove Misfeed :Duplex Unit” Appears

⚠ CAUTION:

- The inside of the machine becomes very hot. Do not touch parts labelled “hot surface”. Touching a “hot surface” could result in a burn.

- 1 If the 2 tray finisher is installed, detach it from the printer.

🔍 Reference

p.81 “Detaching the 2 Tray Finisher”

- 2 Open the left cover of the duplex reversal unit, and then remove the misfed paper. Do not pull the paper out forcefully.

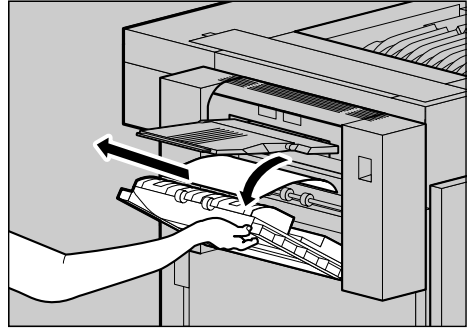

ZHXH700J

If you cannot remove the paper, proceed to step 3.

- 3 Push up the lock release button of the duplex reversal unit, and then hold it in place.

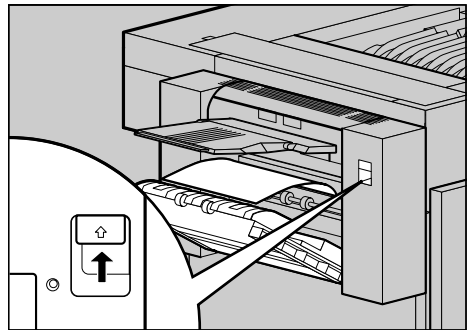

ZHXH710J

- 4 Slowly lower the duplex reversal unit until it stops, and remove the misfed paper.

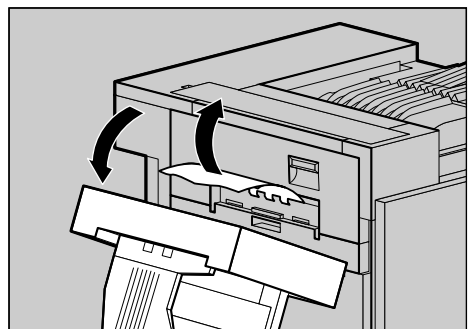

ZDJY212J

- 5 Slowly raise the duplex reversal unit and insert until it clicks into place. Raise the left cover, and then close it securely by pushing the area labeled "PUSH".

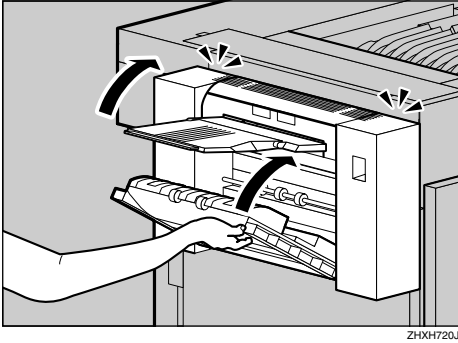

ZHXH720J

Removing Misfed Paper in the Duplex Feed Unit

You can remove misfed paper from the duplex feed unit by following the procedure below.

Note

- When a paper misfeed occurs in the duplex feed unit, the printer usually sends the misfed paper to the right cover, so there is no need to execute this procedure. See p.82 "When "Remove Misfeed A:Internal Path" Appears".

Important

- Be sure to remove misfed paper by following the procedure below when the "Remove Misfeed: Dup. Feed Unit" message appears on the display.

- 1 Turn off the power, and then unplug the power cable.

- 2 Slowly open the front cover of the printer, remove the green screwdriver.

Reference

p.1 "Using the Screwdriver"

- 3 Carefully pivot the waste oil bottle outward, in the direction of the arrow.

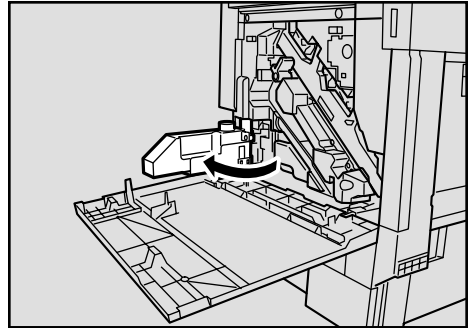

ZHXH150J

CAUTION:

- Keep the waste oil bottle away from flames. There is a risk of fire or burns.

- 4 Remove the screw fastening the duplex feed unit using the provided screwdriver.

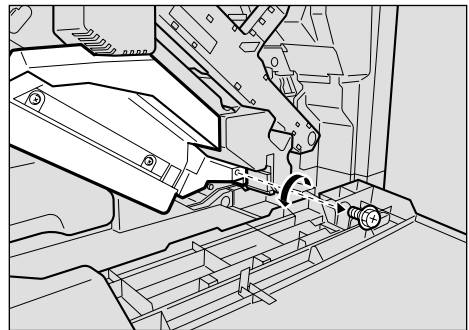

ZHXH320J

You will use this screw to refasten the duplex feed unit later.

- 5** Pinch the upper left area of the duplex feed unit, and then slowly pull it halfway out.

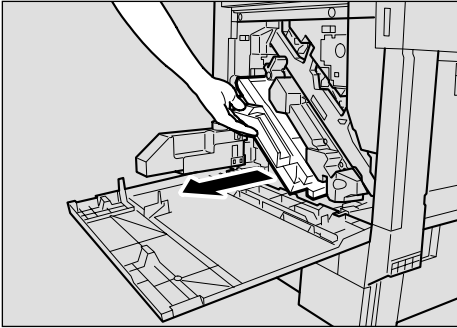

ZHXH780J

- 6** Hold the duplex feed unit using both hands, place it on the vertical rail, and slide it straight out.

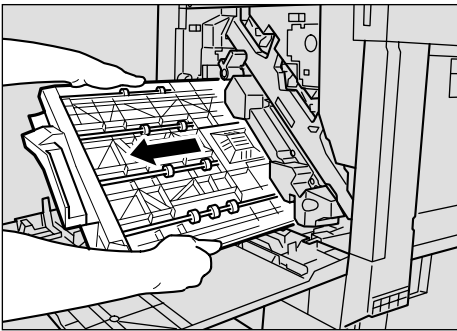

ZHXH650J

- 7** Slowly place the duplex feed unit on the floor. Open it slowly, and remove the misfed paper.

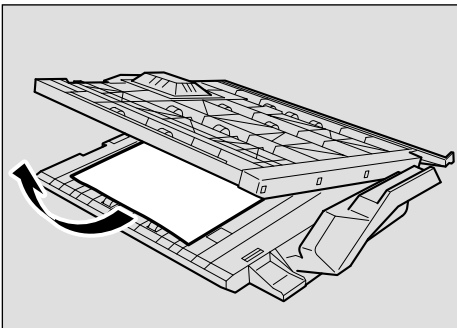

ZHXH660J

Important

- Do not forcefully open the duplex feed unit. It might damage the unit.

- 8** Close the duplex feed unit.

- 9** Hold the duplex feed unit using both hands, place it on the vertical rail, and slide it slowly in until it stops.

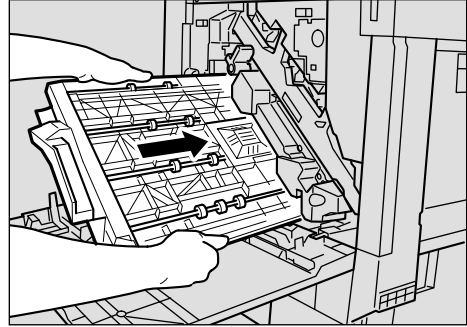

ZHXH290J

The vertical rail is in the position as shown.

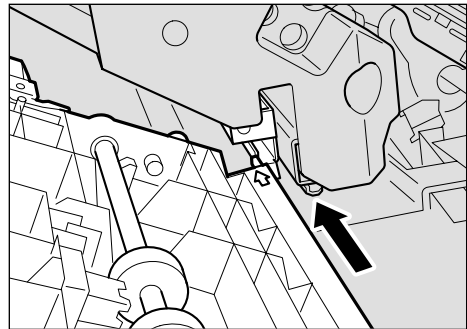

ZHXH300J

- 10** Refasten the duplex feed unit using the provided screwdriver. Use the screw removed in step 4.

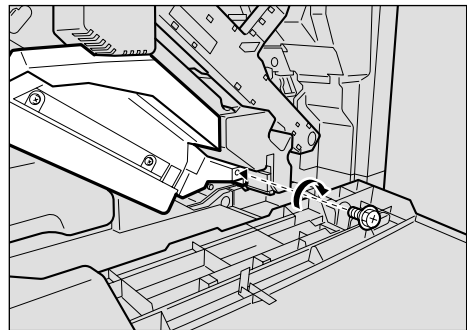

ZHXH310J

Note

- Be sure to return the provided screwdriver to its original position on the inside of the front cover.

- 11** Slowly close the waste oil bottle in the direction of the arrow.

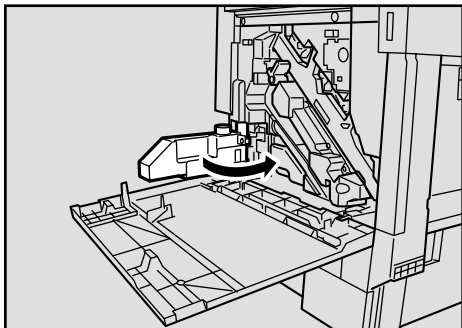

ZHXH160J

4

- 12** Slowly close the front cover by pushing the two areas on the left and right.

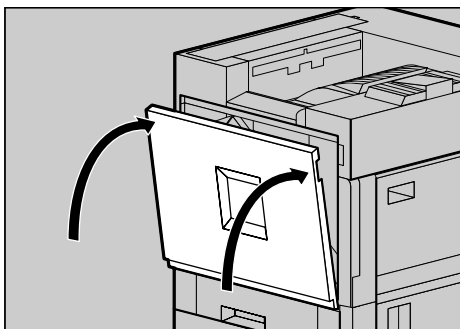

ZDJH041J

- 13** Plug in the power cable, and then turn on the power.

Removing Jammed Staples

If “Add Staples” appears on the display, or the printer does not staple even after instructed, jammed staples might be the cause.

Add Staples

- 1** Open the front cover of the 2 tray finisher.

The stapler is positioned in the location as shown.

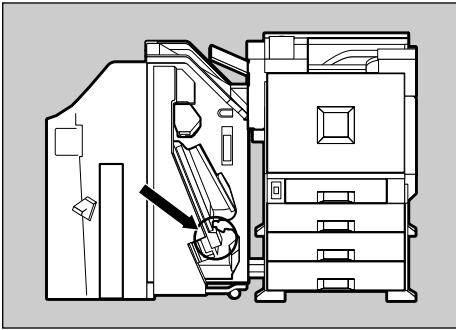

ZHXH730J

- 2** Remove the cartridge by pulling the green knob in the direction of the arrow.

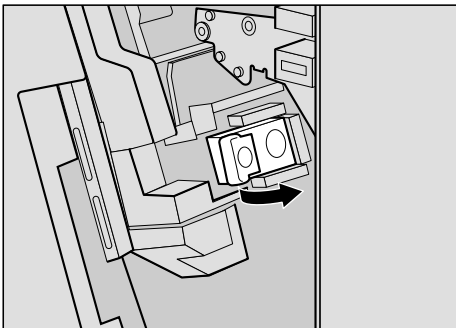

ZDJP217J

- 3** Open the cartridge face plate to unlock it.

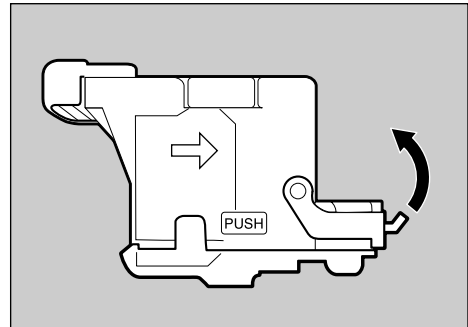

ZDJP227J

- 4** Remove jammed staples.

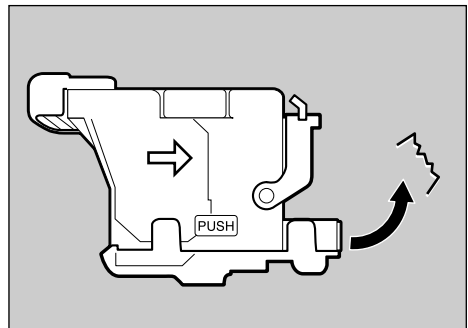

ZDJP228J

- 5** Close the cartridge face plate so it clicks into place.

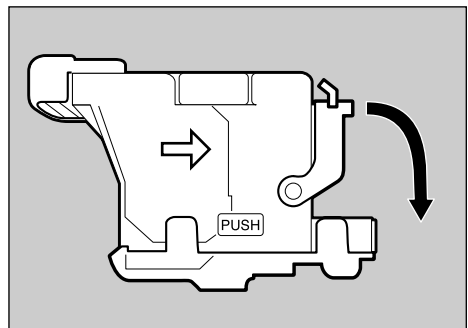

ZDJP229J

- 6** Slant and insert the cartridge (①), and then push in until it clicks into place (②).

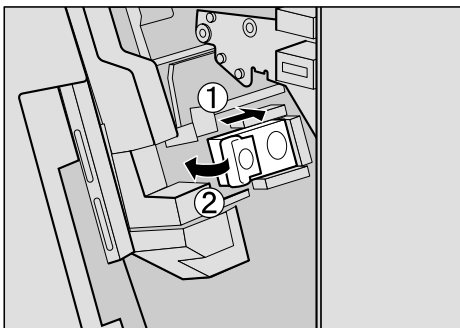

ZDJP218J

4

- 7** Close the front cover of the 2 tray finisher.

Adding Staples

When “Add Staples” appears on the display, add a new staple refill.

Add Staples

- 1** Open the front cover of the 2 tray finisher.

The stapler is positioned in the location as shown.

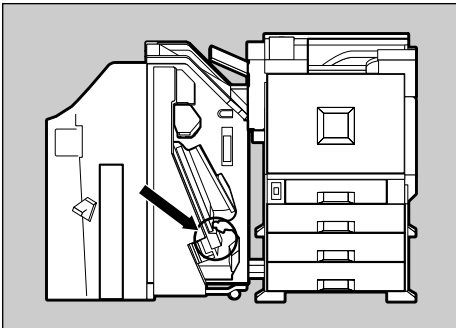

ZHXH730J

- 2** Remove the cartridge by pulling the green knob in the direction of the arrow.

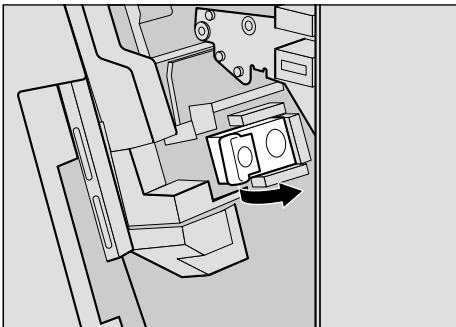

ZDJP217J

- 3** Push the areas labeled “PUSH”, located on both sides of the stapler.

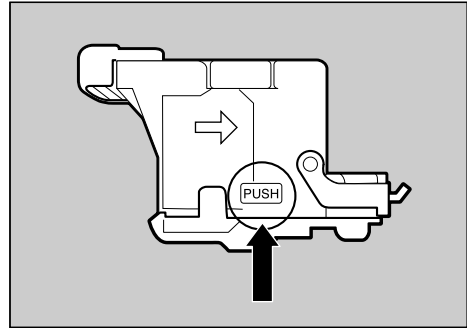

ZDJP222J

The case cover on top rises.

- 4** Pull the case cover up.

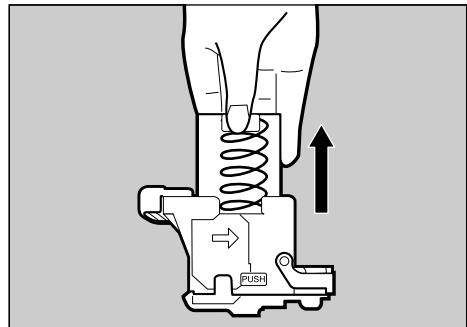

ZDJP223J

- 5** Hook your finger in the hole of the empty refill case to pull it out.

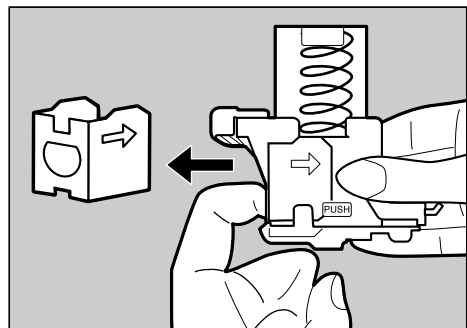

ZDJP224J

- 6** Push in until the arrow on the refill case lines up with the arrow on the refill case cover.

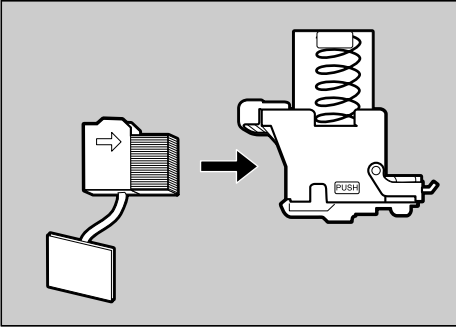

- 9** Slant and insert the cartridge (①), and then push in until it clicks into place (②).

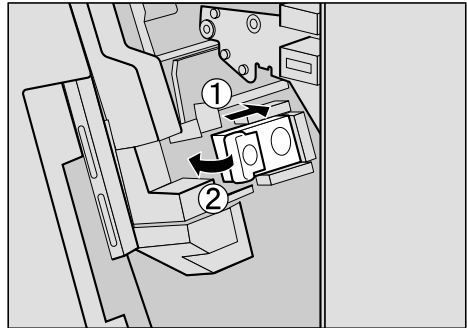

4

- 7** Push the case cover down until it clicks into place.

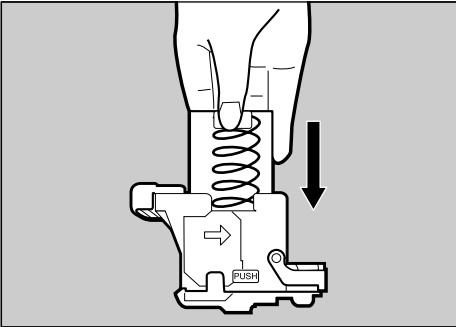

- 10** Close the front cover of the 2 tray finisher.

- 8** Pull out the ribbon used for tying together the staples.

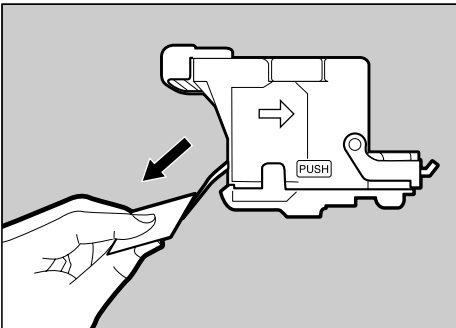

Note

- Remove the entire length of the ribbon.

Removing Punch-hole Chips

When “Punch-hole Chips are Full” appears on the display, the punch waste box is full. Follow these steps to remove paper chips.

Note

- ❑ The same message appears when the punch waste box is not installed correctly.

Punch-hole Chips
are Full

- 1** Open the front cover of the 2 tray finisher.

The punch waste box is positioned in the location shown in the illustration.

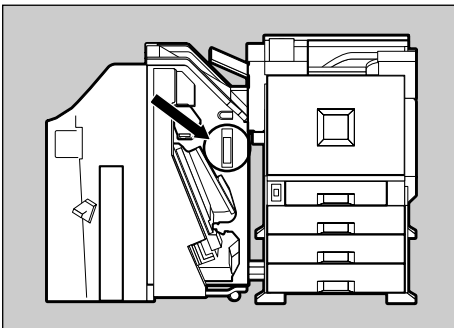

ZHXH740J

- 2** Pull out the punch waste box, and then remove the paper chips.

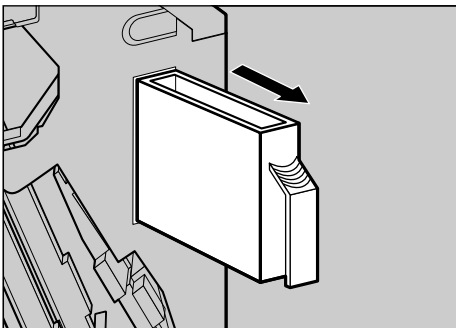

ZDJP220J

- 3** Re-install the punch waste box.

- 4** Close the front cover of the 2 tray finisher.

If the message appears even after removing the Punch-hole chips

If the “Punch-hole Chips are Full” message appears on the control panel even when the punch waste box is not full, chips might be stuck around the punch waste box hole, as shown. Remove punch-hole chips from around the hole.

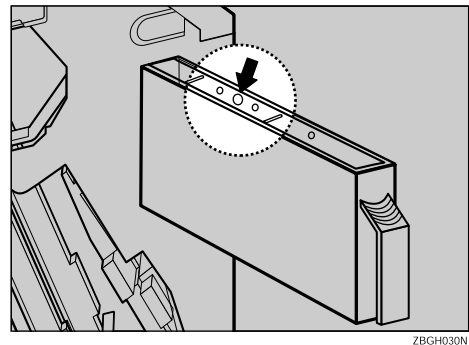

ZBGH030N

5. Appendix

When the Front Cover Does Not Close

If “Close Front Cover” appears on the display, the cover is not properly closed, even if it appears to be.



If the front cover does not close, check the green lever is in the locked position, as shown.

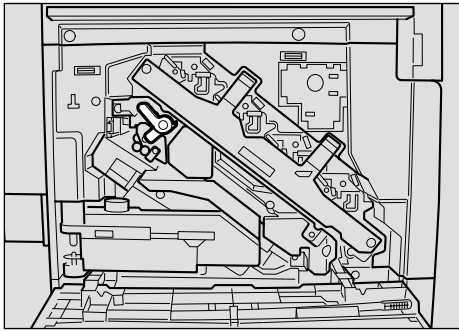

ZHXH020N

1 Turn off the power, and then unplug the power cable.

2 Turn the green lever clockwise.

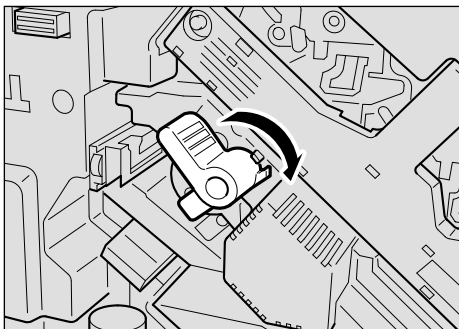

ZHXH420J

3 Slowly close the front cover by pushing the two areas on the left and right.

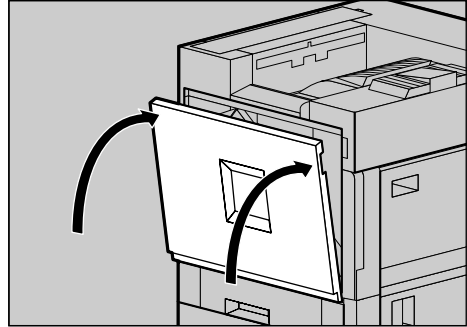

ZDJH041J

4 Plug in the power cable, and then turn on the power.

Moving and Transporting the Printer

CAUTION:

- *When moving the machine, each person should hold the handle on the sides, and lift slowly. Lifting carelessly or dropping it may cause injury.*
- *When moving the printer, remember to unplug the power cord from the wall outlet to avoid fire or electric shock.*
- *When pulling out the plug from the socket, grip the plug to avoid damaging the cord and causing fire or electric shock.*

Note

- The printer weighs approximately 85 kg.

Protect the printer by using the original packaging when transporting.

Important

- Be sure to disconnect all cables from the printer before moving it.
- This printer is a piece of precision machinery. Take care to avoid damage during shipment.

Moving the Printer

CAUTION:

- *When lifting the machine, use the inset grips on both sides. Otherwise the printer could break or cause injury if dropped.*
- *Before moving the machine, unplug the power cord from the outlet. If the cord is unplugged forcefully, it could become damaged. Damaged plugs or cords can cause an electrical or fire hazard.*

Note

- The printer weighs approximately 85 kg.

Moving the printer in the short distance

1 Be sure to check the following:

- The power is turned off.
- The power cable is unplugged from the wall outlet.
- The interface cable is unplugged from the printer.

2 If you have installed external options, remove them.

3 Be sure to close the bypass tray and front cover.

4 Lift the printer and move it horizontally to the place you want to install it.

⚠ Important

- Be sure to move the printer horizontally. Moving the printer slowly prevents toner scattering.
- If the paper feed unit(s) is installed, detach it and move the printer separately.

Consumables

⚠ CAUTION:

- *Our products are engineered to meet the highest standards of quality and functionality. When purchasing expendable supplies, we recommend using only those specified by an authorized dealer.*

❖ Toner cartridge

Toner cartridge	Average printable number of pages per cartridge ^{*1}
Cyan	10,000
Magenta	10,000
Yellow	10,000
Black	20,000

^{*1} A4 5% test chart, 5 pages/job

📝 Note

- The actual number of printed pages you get from a particular toner cartridge depends on the type and size of paper you are using, the contents of print images, and printing environment conditions. This means that toner cartridges may need replacing more frequently than indicated above.
- Toner cartridges that come with the printer are for setup purposes, and will not provide the number of pages described above. The average number of printable pages that can be expected from the toner cartridges included in the printer are as follows:
 - Black toner cartridge : about 10,000 pages
 - Cyan, magenta, and yellow toner cartridges : about 5,000 pages for each cartridge.

❖ Staple Cartridge

Cartridge type	Number of shots
Staple cartridge	5000 shots × 1 with cartridge
Staple Refill cartridge	Refill 5000 shots × 3

❖ Other consumables

Note

- ❑ The actual lifespan of consumables depends on the type and size of paper you are using, the contents of print images, and printing environment conditions. This means that consumables may need replacing more frequently than indicated. Furthermore, the lifespan of color consumables may be considerably reduced, as mixed printing of black & white and color pages is common.

Name	Consumables	Average printable number of pages ^{*1}
Printer Maintenance Kit Type 7000A	Color photoconductor unit × 3	50,000 ^{*2}
Printer Maintenance Kit Type 7000B	Color development unit × 3	100,000 ^{*2}
Printer Maintenance Kit Type 7000C	Fusing unit × 1	100,000 ^{*2}
Printer Maintenance Kit Type 7000D	Black development unit × 1	100,000 ^{*2}
Printer Maintenance Kit Type 3800E	Waste toner bottle × 1	50,000
Printer Maintenance Kit Type 7000F	Black photoconductor unit × 1	50,000 ^{*2}
Printer Maintenance Kit Type 7000G	Fuser oil unit × 1	30,000 ^{*2}
Printer Maintenance Kit Type 3800H	Paper feed rollers × 1	150,000

^{*1} A4 5% test chart, 5 pages/job

^{*2} When printing each page as a single job, the unit needs extra idling time, thus reducing its print life by half.

INDEX

A

- Adding Staples, 93
- Adjusting Image Density, 36
- Adjusting the Color Registration, 32
 - Auto Adjust*, 32
- Adjusting Tray Registration, 37
- Appendix, 97

B

- Bypass Tray
 - Custom Size*, 58
 - Paper Type*, 59

C

- Cleaning and Adjusting the Printer, 29
- Cleaning the DustProof Glass, 31
- Cleaning the Registration Roller, 30
- Color Adjustment
 - Checking the Test Sheet*, 35
- Consumables, 100

D

- Data In indicator, 75
- Detaching the 2 Tray Finisher, 81
- Detaching the SR770 (2 Tray Finisher), 5
- Display panel, messages, 61

E

- Envelopes, 46
- Error, 61
- Error indicator, 74

L

- Loading Paper, 45, 50
 - Optional Paper Feed Unit*, 51
 - Tray 1*, 50
 - Tray 2*, 51
- Loading paper
 - Bypass Tray*, 56
 - Paper Bank PS470*, 52
 - paper size*, 53
 - paper type*, 55

M

- messages, 61
- Moving the Printer, 98

O

- OHP transparencies, 46
- Online indicator, 74
- Online key, 74
- Opening and Closing the Duplex Reversal Unit, 6, 81
- Other Printing Problems, 77

P

- Paper and Other Media, 39
- Paper Size, 39
- Plain Paper, 45
- Printable Area, 49
- Printer Does Not Print, 74

R

- Remove Misfed Paper
 - Duplex Unit*, 87
 - Finisher*, 85
 - Fusing Unit*, 83
 - Internal Path*, 82
 - Mailbox*, 84
 - Paper Tray*, 87
- Removing Jammed Staples, 91
- Removing Misfed Paper, 81
- Removing Misfed Paper into the Duplex Feed Unit, 88
- Removing Punch-hole Chips, 95
- Replacing Consumables and Maintenance Kit, 1
- Replacing the Development Unit, 15
- Replacing the Dustproof Filter, 22
- Replacing the Fuser Oil Unit, 7
- Replacing the Fusing Unit, 19
- Replacing the Photoconductor Unit, 11
- Replacing the Toner Cartridge, 2
- Replacing the Waste Toner Bottle, 24

S

Screwdriver, 1
Storing Paper, 45

T

Thick Paper, 46
Toner Cartridge, 100
Troubleshooting, 61

W

When the Front Cover Does Not Close, 97

